

AccuDrive Family of Products



Series W



Series S



Model RG



Series P



CONEDRIVE™
GEARING SOLUTIONS

ACCUDRIVE PRECISION PRODUCTS

Now you can get design flexibility and lasting performance from our complete family of AccuDrive Precision Products.

Series W Precision Servo Gearhead

Output torque up to 8,500 lb.in.
Motor adapters to fit servo motors.
Center distance from 38 to 89 mm.
Speed range up to 6,000 RPM input.
Sizes available 38, 51, 64, 76 and 89.
Universal Mounting with shaft mount and flange mount standard.
Gear ratios from 5:1 to 60:1, special ratios available.
Standard backlash, low backlash and ZERO backlash available.



Series S Servo Gearhead

Economical Servo Solution
Output torque up to 7,540 Lb.In.
Motor adapters to fit servo motors
Center distance from 1.54 inch up to 3.54 inch
Speed range up to 4,000 RPM
Flexible mounting (hollow output standard with plug in solid shaft)
Ratios from 5:1 to 60:1



Series P In-line Planetary Servo Gearhead

Output torque capacity up to 15,930 lb.in.
Motor adapters to fit servo motors.
Center distance from 70 to 190 mm.
Speed range up to 10,000 RPM input.
Sizes available 70, 90, 115, 142 and 190.
Gear ratios from 3:1 to 40:1 available from stock.
Universal Mounting with shaft mount and flange mount standard.
Three arcminutes backlash or better.



Model RG Right Angle Gearhead

Output torque capacity up to 8,500 lb.in.
Motor sizes (standard), adapters to fit servo motors, NEMA and IEC.
Center distance from 1.5 to 3.5 inches.
Input power ratings up to 27 H.P, speed range up to 4,000 RPM.
Sizes available 15, 20, 25, 30 and 35.
Universal Mounting with shaft mount and flange mount standard in single reduction type.
Gear ratios from 5:1 to 60:1.



ABSOLUTE ZERO Backlash AccuDrive Gearing

Unique design captures both sides of the gear tooth to completely eliminate backlash. Automatically compensates for wear-guaranteed zero backlash for the life of the gearset. Available for single, double and triple reduction types, gear sets, special designs and the Series W.

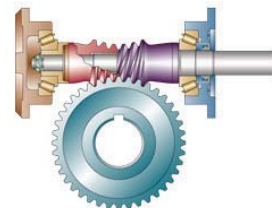

Table of contents

	Design Features - - - - -	2
Series E	Introduction - - - - -	3
	20 - Digit Code - Current Design - - - - -	4 - 5
	Motor Mounting Codes - Current Design - - - - -	6
	Output torque Ratings - - - - -	7
	Additional Ratings - - - - -	8
	Gearhead Inertia - - - - -	9
	Backlash Table - - - - -	10
	Drawings for C-Face Output - - - - -	11
	Drawings for D-Flange Output - - - - -	12
Series LE	Introduction - - - - -	13
	20 - Digit Code - - - - -	14 - 15
	Motor Mounting Codes - - - - -	16
	Output torque Ratings - - - - -	17
	Additional Ratings - - - - -	18
	Gearhead Inertia - - - - -	19
	Backlash Table - - - - -	20
	Drawings - - - - -	21
	Sizing and Selection - - - - -	22
Installation and Maintenance - - - - -	23	

Cone Drive is proud to offer both the Series E and LE planetary servo gearheads. The Series E offers higher performance while the Series LE is a dimensional drop-in for most of the planetary gearhead manufacturers.



	Series E	Series LE
Backlash	●	●
Radial Load	○	●
Output Torque	●	○
Lifetime	●	○
Range of Ratios	●	○
Output Flange Options	●	○
Interchangeable	○	●

The Series E Product Family Advantages

Precision Honed Planetary Gearing

- Lower noise levels
- Higher speeds
- Consistent backlash
- Greater precision

Greater Number of Planet Gears

- Higher torque ratings
- Longer lifetime
- Less downtime

Hardened Ring gear

- Higher torque ratings
- Improved lifetime

No-Slip Input Clamping Design

- No registration errors
- No downtime
- No damaged shafts

More Output Mounting Options

- Design flexibility
- Engineering cost savings
- Part reduction

Engineering Assistance

Series E

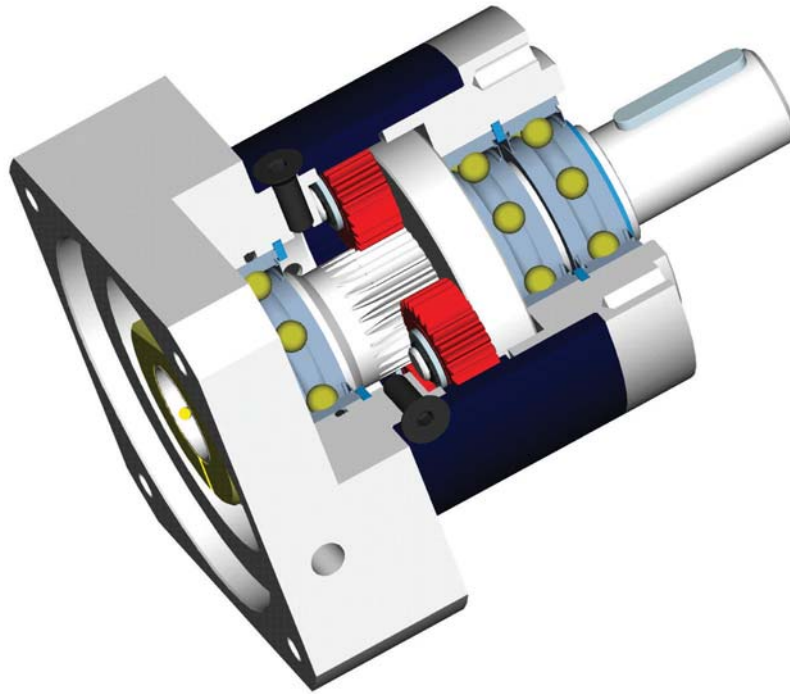

The Series E is the legacy product and offers the highest ratings and durability with a wide range of ratios.

- Precision clamping system to eliminate motor shaft slipping.
- Precision honed gearing for lower noise at higher speeds.
- Integral output shaft and planet carrier
- Carbon steel and hardened honed ring gear integral to the housing. Providing low noise, minimum wear and consistent low backlash.
- Grease lubricated for life.

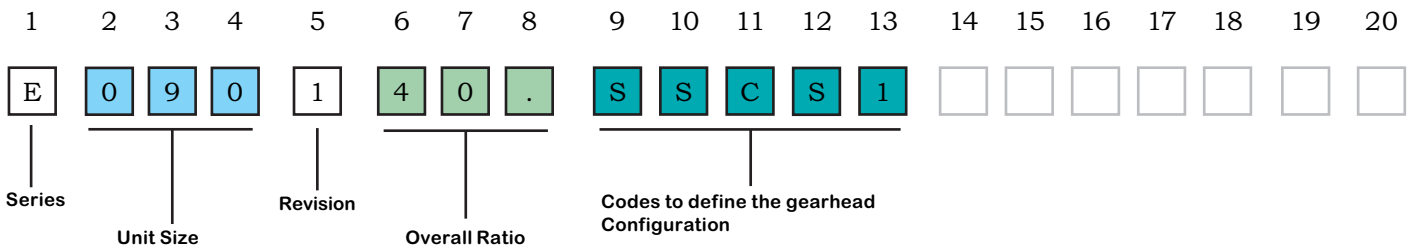

Step 1

Series of Gearhead

Code Position : 1

Example Code : E

Step 2

Size of Gearhead

Code Position : 2 3 4

Example Code : 0 9 0

Options:

0	4	0	1	1	5
0	6	0	1	6	0
0	9	0			

Step 3

Revision Level

Code Position : 5

Example Code : 1

Step 4

Overall Ratio

Code Position : 6 7 8

Example Code : 4 0 .

Options:

Single Reduction			Double Reduction					
3	.	0	9	.	0	6	0	.
4	.	0	1	2	.	8	0	.
5	.	0	1	5	.	1	0	0
8	.	0	1	6	.	1	2	0
			2	0	.	1	6	0
			2	5	.	2	0	0
			3	2	.	2	5	6
			4	0	.	3	2	0
			6	4	.	5	1	2



Step 5

Backlash Level

Code Position : 9

Example Code : S

Options : S-Standard Backlash

Step 6

Type of Unit

Code Position : 10

Example Code : S

Options: S - Fits Servo Motor

Step 7

Output Type

Code Position : 11

Example Code : C

Options:

- C Standard C-Face
- N NEMA Flange
- D D-Flange

Step 8

Motor Type

Code Position : 12

Example Code : S

Options: S - Fits a Servo Motor

Step 9

Assembly Position

Code Position : 13

Example Code : 1

Options: 1 - Single Extended Output

1	2	3	4	5	6	7	8	9	10	11	12	13	14	15	16	17	18	19	20
E	0	9	0	1	4	0	.	S	S	C	S	1	D	H	L	D	K	G	-

Step 10

Motor Shaft Length

Code Position : 14

Example Code : **D**

See Page 6 for motor shaft length code

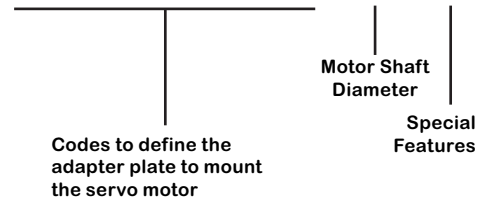
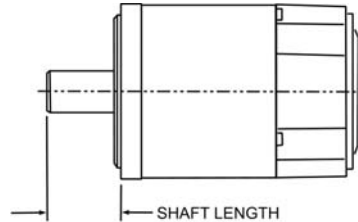

Step 11

Motor Flange Square

Code Position : 15

Example Code : **H**

See Page 6 for motor flange square code

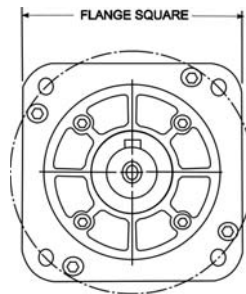

Step 14

Motor Bolt Hole Diameter

Code Position : 18

Example Code : **K**

See Page 6 for motor bolt hole diameter code

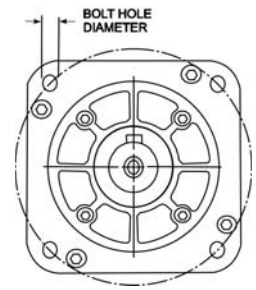

Step 12

Motor Pilot Diameter

Code Position : 16

Example Code : **L**

See Page 6 for motor pilot diameter code

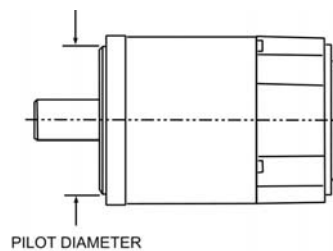

Step 15

Motor Shaft Diameter

Code Position : 19

Example Code : **G**

See Page 6 for motor shaft diameter code

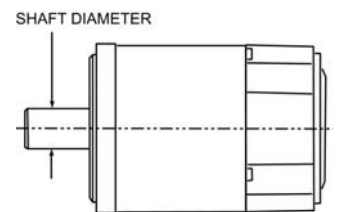

Step 13

Motor Bolt Circle Diameter

Code Position : 17

Example Code : **D**

See Page 6 for motor bolt circle diameter code

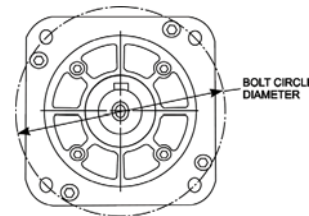

Step 16

Special Features

Code Position : 20

Example Code : **-**

Options:

- No special features
- S** Stainless steel paint
- W** White epoxy paint

MOTOR MOUNTING CODES - CURRENT DESIGN

E040 SELECTIONS	COLUMN 14 ENTRY	SHAFT LENGTH									
		25									
		M									
	COLUMN 15 ENTRY	FLANGE SQUARE									
		40	60								
		M	P								
COLUMN 16 ENTRY	PILOT DIAMETER										
	20.02	30	38.1								
	S	T	A								
COLUMN 17 ENTRY	BOLT CIRCLE										
	46	46.7	66.68								
	V	W	C								
COLUMN 18 ENTRY	BOLT HOLE DIAMETER IN MOTOR FLANGE										
	3.2 - 3.6	4.3 - 4.8									
	J	K									
COLUMN 19 ENTRY	MOTOR SHAFT DIAMETER										
	4	.5	6	6.35	8						
	X	Y	Z	A	B						

E060 SELECTIONS	COLUMN 14 ENTRY	SHAFT LENGTH									
		23	25	30	32	40					
		A	M	B	C	D					
	COLUMN 15 ENTRY	FLANGE SQUARE									
		60	70	80	90						
		P	A	B	C						
COLUMN 16 ENTRY	PILOT DIAMETER										
	30	38.1	40	50	60	70	73.07				
	T	A	B	C	D	E	F				
COLUMN 17 ENTRY	BOLT CIRCLE										
	46	63	65	66.68	70	75	80	90	95	98.43	
	V	A	B	C	D	E	F	G	H	J	
COLUMN 18 ENTRY	BOLT HOLE DIAMETER IN MOTOR FLANGE										
	4.5 - 5.2	5.3 - 6.3	6.4 - 8.3								
	A	B	C								
COLUMN 19 ENTRY	MOTOR SHAFT DIAMETER										
	6	6.35	8	9	9.525	10	11	12	12.7	14	
	Z	A	B	C	D	E	F	G	H	J	

E090 SELECTIONS	COLUMN 14 ENTRY	SHAFT LENGTH									
		30	32	40	50	58					
		B	C	D	F	G					
	COLUMN 15 ENTRY	FLANGE SQUARE									
		80	90	100	115	120					
		B	C	D	E	F					
COLUMN 16 ENTRY	PILOT DIAMETER										
	38.1	40	50	60	70	73.07	80	95	110		
	A	B	C	D	E	F	G	H	J		
COLUMN 17 ENTRY	BOLT CIRCLE										
	66.68	70	75	80	90	95	98.43	100	115	130	145
	C	D	E	F	G	H	J	K	L	M	N
COLUMN 18 ENTRY	BOLT HOLE DIAMETER IN MOTOR FLANGE										
	4.5 - 5.2	5.3 - 6.3	6.4 - 8.3	8.4 - 10.3							
	A	B	C	D							
COLUMN 19 ENTRY	MOTOR SHAFT DIAMETER										
	9.525	10	11	12	12.7	14	16	19			
	D	E	F	G	H	J	K	L			

E115 SELECTIONS	COLUMN 14 ENTRY	SHAFT LENGTH									
		40	45	50	58						
		D	E	F	G						
	COLUMN 15 ENTRY	FLANGE SQUARE									
		115	120	140							
		E	F	G							
COLUMN 16 ENTRY	PILOT DIAMETER										
	80	70	73.07	95	110	130					
	G	E	F	H	J	L					
COLUMN 17 ENTRY	BOLT CIRCLE										
	90	98.43	100	115	130	145	165				
	G	J	K	L	M	N	P				
COLUMN 18 ENTRY	BOLT HOLE DIAMETER IN MOTOR FLANGE										
	5.3 - 6.3	6.4 - 8.3	8.4 - 10.3	10.4 - 12.4							
	B	C	D	E							
COLUMN 19 ENTRY	MOTOR SHAFT DIAMETER										
	11	12.7	14	16	19	22	24				
	F	H	J	K	L	M	N				

E160 SELECTIONS	COLUMN 14 ENTRY	SHAFT LENGTH									
		50	58	60	80						
		F	G	H	J						
	COLUMN 15 ENTRY	FLANGE SQUARE									
		140	180	190							
		G	H	J							
COLUMN 16 ENTRY	PILOT DIAMETER										
	110	114.3	130	180							
	J	K	L	M							
COLUMN 17 ENTRY	BOLT CIRCLE										
	130	145	165	200	215						
	M	N	P	Q	R						
COLUMN 18 ENTRY	BOLT HOLE DIAMETER IN MOTOR FLANGE										
	8.4 - 10.3	10.4 - 12.4	12.5 - 15								
	D	E	F								
COLUMN 19 ENTRY	MOTOR SHAFT DIAMETER										
	19	24	28	32	35						
	L	N	P	Q	R						

1. Use the tables on this page to determine Columns 14 - 19 of your 20 digit order code(page 5).
2. First, choose the appropriate table for the Series E unit size you have selected: E040, E060, E090, E115, or E160. Detailed specifications for each unit are given on pages 4-6 of this catalog.
3. Then select the appropriate codes for Columns 14-19 by matching the dimensions on your servo motor flange to the codes listed in the respective table.
4. If you need assistance, please contact Cone Drive customer service.

Series E

OUTPUT TORQUE RATINGS

Ratios	Gear Stages		Output Torque by Gearhead Size									
			E040		E060		E090		E115		E160	
			T _{2N}	T _{MAX}	T _{2N}	T _{MAX}	T _{2N}	T _{MAX}	T _{2N}	T _{MAX}	T _{2N}	T _{MAX}
3	1	lb.In.	97	150	245	398	752	1203	1018	1628	3540	5664
		Nm	11	17	28	45	85	136	115	184	400	640
4	1	lb.In.	133	212	336	540	1018	1628	1372	2531	3982	6372
		Nm	15	24	38	61	115	184	155	248	450	720
5	1	lb.In.	124	194	354	566	973	1558	1726	2761	3982	6372
		Nm	14	22	40	64	110	176	195	312	450	720
8	1	lb.In.	53	88	160	256	442	708	1062	1699	3982	6372
		Nm	6	10	18	29	50	80	120	192	450	720
9	2	lb.In.	142	230	389	619	1150	1840	1858	2973	-	-
		Nm	16	26	44	70	130	208	210	336	-	-
12	2	lb.In.	177	283	389	619	1062	1699	2301	3681	7080	11328
		Nm	20	32	44	70	120	192	260	416	800	1280
15	2	lb.In.	159	256	389	619	973	1558	2035	3257	6195	9912
		Nm	18	29	44	70	110	176	230	368	700	1120
16	2	lb.In.	177	283	389	619	1062	1699	2301	3681	7080	11328
		Nm	20	32	44	70	120	192	260	416	800	1280
20	2	lb.In.	177	283	389	619	1062	1699	2301	3681	7080	11328
		Nm	20	32	44	70	120	192	260	416	800	1280
25	2	lb.In.	159	256	354	566	973	1558	2035	3257	6195	9912
		Nm	18	29	40	64	110	176	230	368	700	1120
32	2	lb.In.	177	283	389	619	1062	1699	2301	3681	7080	11328
		Nm	20	32	44	70	120	192	260	416	800	1280
40	2	lb.In.	159	256	354	566	973	1558	2035	3257	6195	9912
		Nm	18	29	40	64	110	176	230	368	700	1120
64	2	lb.In.	66	106	159	256	442	708	1062	1699	3982	6372
		Nm	7.5	12	18	29	50	80	120	192	450	720
60	3	lb.In.	177	283	389	619	973	1558	2301	3681	-	-
		Nm	20	32	44	70	110	176	260	416	-	-
80	3	lb.In.	177	283	389	619	1062	1699	2301	3681	-	-
		Nm	20	32	44	70	120	192	260	416	-	-
100	3	lb.In.	177	283	389	619	1062	1699	2301	3681	-	-
		Nm	20	32	44	70	120	192	260	416	-	-
120	3	lb.In.	159	256	389	619	973	1558	2035	3257	-	-
		Nm	18	29	44	70	110	176	230	368	-	-
160	3	lb.In.	177	283	389	619	1062	1699	2301	3681	-	-
		Nm	20	32	44	70	120	192	260	416	-	-
200	3	lb.In.	159	256	354	566	973	1558	2035	3257	-	-
		Nm	18	29	40	64	110	176	230	368	-	-
256	3	lb.In.	177	283	389	619	1062	1699	2301	3681	-	-
		Nm	20	32	44	70	120	192	260	416	-	-
320	3	lb.In.	159	256	354	566	973	1558	2035	3257	-	-
		Nm	18	29	40	64	110	176	230	368	-	-
512	3	lb.In.	66	106	159	256	442	708	1062	1699	-	-
		Nm	7.5	12	18	29	50	80	120	192	-	-

T_{2N} = Continuous duty rated torque, at uniform load, 30000 hours L10 design life, at 100 rpm output shaft speed
 T_{MAX} = Maximum torque allowable for 30000 output shaft rotations

	Gear Stages		Size				
			E040	E060	E090	E115	E160
Emergency Stop			$2 \times T_{2N}$				
Maximum Radial Load		lbs.	36.0	76.4	146.1	337.2	944.2
		N	160	340	650	1500	4200
Maximum Axial Load		lbs.	36.0	101.2	202.3	472.1	1348.8
		N	160	450	900	2100	6000
Efficiency	1	%	96				
	2	%	94				
	3	%	90				
Average Lifetime		Hours	30,000				
Weight	1	lbs.	0.77	1.9	4.6	13.2	39.6
		kg.	0.35	0.9	2.1	6.0	18.0
	2	lbs.	0.99	2.4	5.7	17.6	48.5
		kg.	0.45	1.1	2.6	8.0	22.0
	3	lbs.	1.20	2.8	6.8	22.0	-
		kg.	0.55	1.3	3.1	10.0	-
Maximum motor weight	1, 2, 3	lbs.	4.40	7.7	19.8	35.2	110.0
		kg.	2.00	3.5	9.0	16.0	50.0

Series E

GEARHEAD INERTIA

	Ratios	Gear Stages		Size				
				E040	E060	E090	E115	E160
Moment of Inertia	3	1	lb.in.s2 x 10-4	0.270	1.190	6.80	23.2	107.4
			kgcm2	0.031	0.135	0.77	2.63	12.14
	4		lb.in.s2 x 10-4	0.190	0.820	4.60	15.8	68.8
			kgcm2	0.022	0.093	0.52	1.79	7.78
	5		lb.in.s2 x 10-4	0.160	0.690	3.90	13.5	53.7
			kgcm2	0.019	0.078	0.45	1.53	6.07
	8	lb.in.s2 x 10-4	0.150	0.570	3.40	11.6	40.9	
		kgcm2	0.017	0.065	0.39	1.32	4.63	
	9	2	lb.in.s2 x 10-4	0.260	1.150	6.54	23.1	-
			kgcm2	0.030	0.131	0.74	2.62	-
	12	lb.in.s2 x 10-4	0.250	1.120	6.30	22.6	109.0	
		kgcm2	0.029	0.127	0.72	2.56	12.37	
	15	lb.in.s2 x 10-4	0.200	0.680	6.28	22.3	109.0	
		kgcm2	0.023	0.077	0.71	2.53	12.35	
	16	lb.in.s2 x 10-4	0.190	0.770	4.40	15.4	66.0	
		kgcm2	0.022	0.088	0.50	1.75	7.47	
	20	lb.in.s2 x 10-4	0.160	0.660	3.80	13.2	58.8	
		kgcm2	0.019	0.075	0.44	1.5	6.65	
	25	lb.in.s2 x 10-4	0.160	0.660	3.80	13.1	51.4	
		kgcm2	0.019	0.075	0.44	1.49	5.81	
	32	lb.in.s2 x 10-4	0.150	0.560	3.40	11.5	56.2	
		kgcm2	0.017	0.064	0.39	1.30	6.36	
	40	lb.in.s2 x 10-4	0.140	0.560	3.40	11.5	46.7	
		kgcm2	0.016	0.064	0.39	1.30	5.28	
	64	lb.in.s2 x 10-4	0.140	0.560	3.40	11.5	39.8	
		kgcm2	0.016	0.064	0.39	1.30	4.50	
	60	3	lb.in.s2 x 10-4	0.260	0.670	4.510	22.74	-
			kgcm2	0.029	0.076	0.510	2.570	-
	80	lb.in.s2 x 10-4	0.160	0.660	4.40	13.2	-	
		kgcm2	0.019	0.075	0.50	1.50	-	
	100	lb.in.s2 x 10-4	0.160	0.660	3.80	13.1	-	
		kgcm2	0.019	0.075	0.44	1.49	-	
120	lb.in.s2 x 10-4	0.250	0.560	6.10	22.1	-		
	kgcm2	0.029	0.064	0.70	2.50	-		
160	lb.in.s2 x 10-4	0.140	0.560	3.45	11.5	-		
	kgcm2	0.016	0.064	0.39	1.30	-		
200	lb.in.s2 x 10-4	0.140	0.560	3.45	11.5	-		
	kgcm2	0.016	0.064	0.39	1.30	-		
256	lb.in.s2 x 10-4	0.140	0.560	3.45	11.5	-		
	kgcm2	0.016	0.064	0.39	1.30	-		
320	lb.in.s2 x 10-4	0.140	0.560	3.45	11.5	-		
	kgcm2	0.016	0.064	0.39	1.30	-		
512	lb.in.s2 x 10-4	0.140	0.560	3.45	11.5	-		
	kgcm2	0.016	0.064	0.39	1.30	-		

	Gear Stages		Size				
			E040	E060	E090	E115	E160
Backlash	1	arcmin.	<15	<12	<8	<8	<6
	2	arcmin.	<19	<15	<12	<12	<10
	3	arcmin.	<22	<18	<14	<14	-
Torsional Stiffness (per arcminute)	1	lb.in./arcmin	8.9	20.4	53.1	106.2	336.3
		Nm/arcmin	1.0	2.3	6.0	12.0	38.0
	2	lb.in./arcmin	9.7	22.1	57.5	115.1	362.9
		Nm/arcmin	1.1	2.5	6.5	13.0	41.0
	3	lb.in./arcmin	8.9	22.1	55.8	106.2	-
		Nm/arcmin	1.0	2.5	6.3	12.0	-
Running Noise		dB(A)	58	58	60	65	70
Max. input speed		RPM	18000	13000	7000	6500	6500
Cont. input speed		RPM	5000	4500	4000	3500	3000

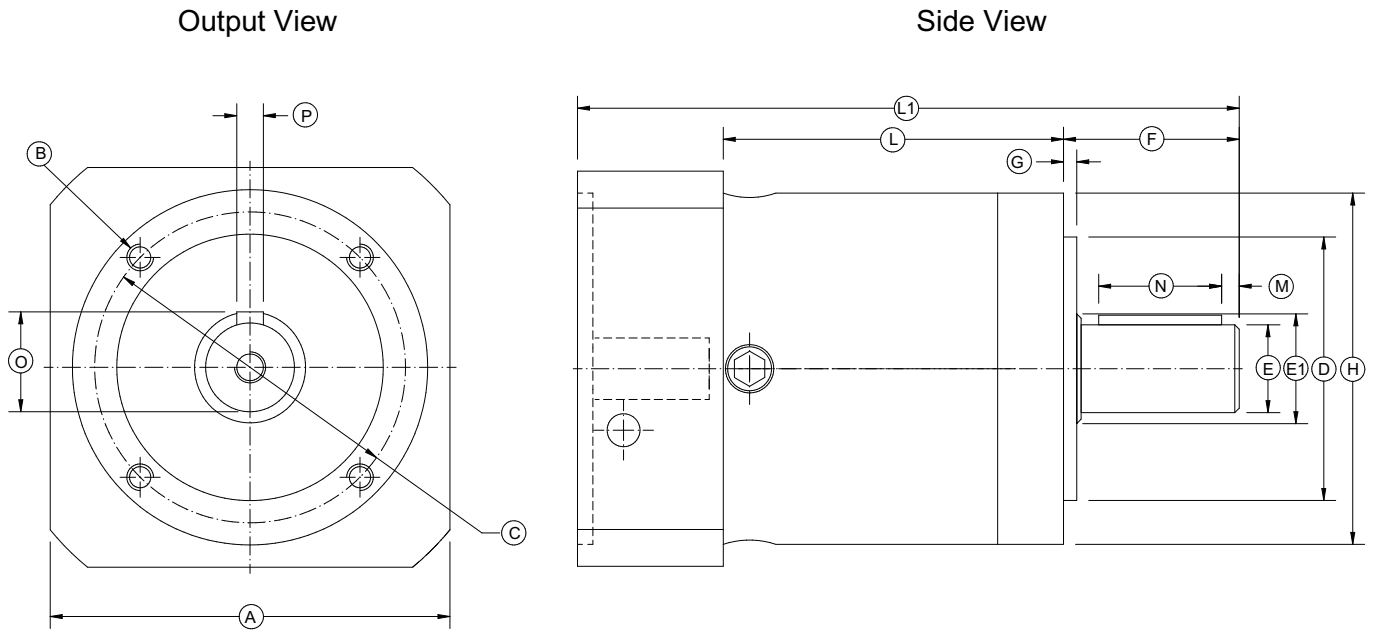

Standard Unit with C-FACE Output

Unit Size	A		B	C		D		E		E1		F		G		H	
	Input Flange Square			Mounting Hole Thread	Bolt Circle Diameter		Pilot Diameter		Shaft Diameter		Shaft Shoulder Diameter		Output Shaft Length from Flange		Pilot Depth		Housing Diameter
	Inch	mm	Inch		mm	Inch	mm	Inch	mm	Inch	mm	Inch	mm	Inch	mm	Inch	mm
E040	1.574	40	M4 X 6	1.338	34	1.023	26	0.393	10	0.482	12	1.023	26	0.078	2	1.574	40
E060	2.362	60	M5 X 8	2.047	52	1.574	40	0.551	14	0.669	17	1.377	35	0.118	3	2.362	60
E090	3.150	80	M6 X 10	2.755	70	2.362	60	0.787	20	0.984	25	1.574	40	0.118	3	3.15	80
E115	4.527	115	M10 X 16	3.937	100	3.149	80	0.984	25	1.377	35	2.165	55	0.157	4	4.527	115
E160	6.299	160	M12 X 20	5.708	145	5.118	130	1.574	40	2.165	55	3.425	87	0.196	5	6.299	160

Unit Size	L						L1			M		N		O		P	
	Body Length						Body Length			Distance from End of Shaft	Keyway Length		Key & Shaft Height		Keyway Width		
	1 stage		2 stage		3 stage		1 stage	2 stage	3 stage		Inch	mm	Inch	mm	Inch	mm	Inch
E040	1.535	39	2.040	52	2.519	64	Gearhead length from motor plate to the end of the output shaft will vary depending on the motor selection. Please contact Cone Drive Engineering if length is critical to application to get exact gearhead length.			0.098	2.5	0.708	18	0.440	11.2	0.118	3
E060	1.850	47	2.322	59	2.834	72				0.098	2.5	0.984	25	0.629	16	0.196	5
E090	2.381	60.5	3.051	77.5	3.740	95				0.157	4	1.102	28	0.885	22.5	0.236	6
E115	2.913	74	3.976	101	5.039	128				0.196	5	1.574	40	1.102	28	0.314	8
E160	4.094	104	6.043	153.5	-	-				0.314	8	2.559	65	1.692	43	0.472	12

**L” and “L1” dimensions may vary for longer than standard motor shaft dimensions.

DRAWINGS FOR D-FLANGE OUTPUT

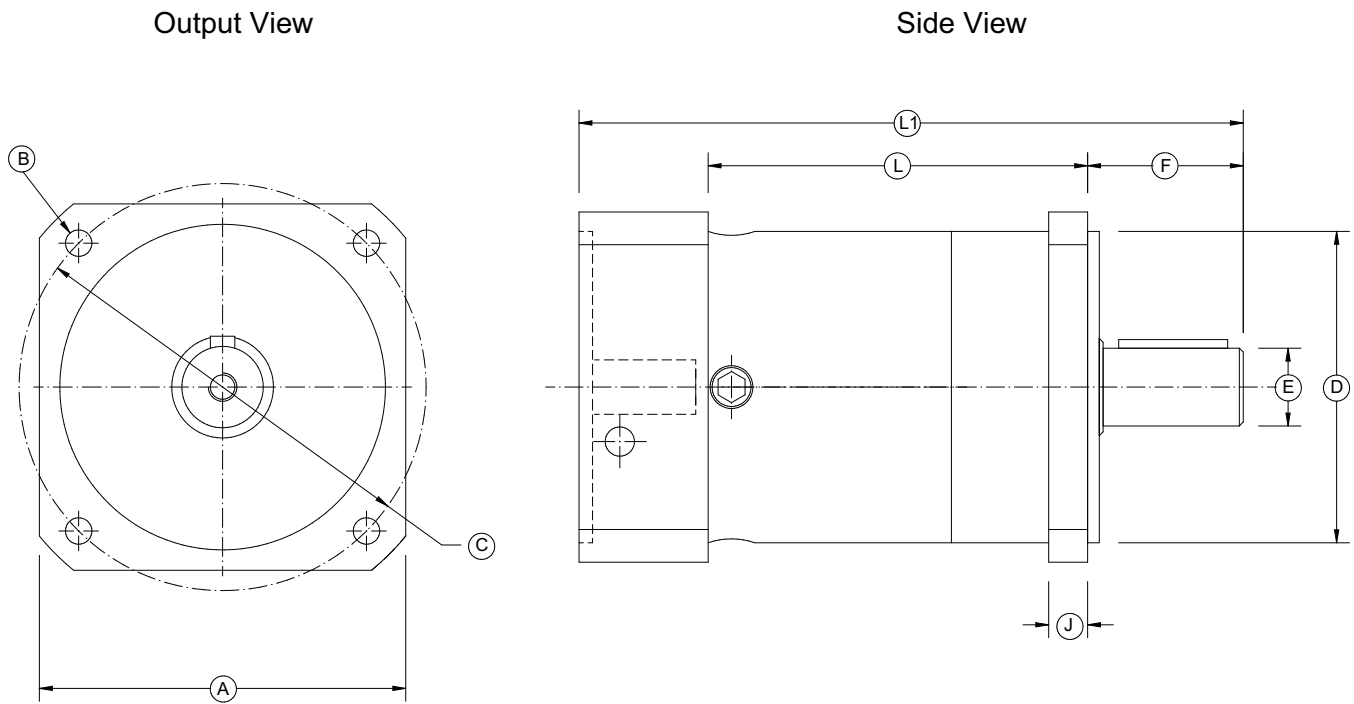

Optional NEMA Flange Output

Unit Size	A		B		C		D		E		F		J		L					
	Output Flange Square		Bolt Hole		Bolt Circle Diameter		Pilot Diameter		Shaft Diameter		Output Shaft Length from Flange		Flange Thickness		Body Length					
	Inch	mm	Inch	mm	Inch	mm	Inch	mm	Inch	mm	Inch	mm	Inch	mm	1 stage		2 stage		3 stage	
E060 ¹	2.36	60	0.177	4.5	2.63	66.7	1.500	38.1	0.55	14	0.94	24	0.43	11	2.28	58.0	2.76	70.0	3.27	83
E090 ²	3.26	83	0.217	5.5	3.87	98.4	2.874	73.0	0.78	20	1.1	28	0.47	12	2.85	72.5	3.52	89.5	4.21	107
E115 ³	5.00	127	3/8-16		5.88	149	4.500	114	0.98	25	1.34	34	0.63	16	3.07	78.0	4.13	105	5.2	132

- 1. Output flange is Nema23
- 2. Output flange is Nema34
- 3. Output flange is Nema56C

Optional Metric D Flange Output

Unit Size	A		B		C		D		E		F		J		L					
	Output Flange Square		Bolt Hole		Bolt Circle Diameter		Pilot Diameter		Shaft Diameter		Output Shaft Length from Flange		Flange Thickness		Body Length					
	Inch	mm	Inch	mm	Inch	mm	Inch	mm	Inch	mm	Inch	mm	Inch	mm	1 stage		2 stage		3 stage	
E060	2.756	70	0.217	5.5	2.953	75	2.362	60	0.630	16k6	1.260	32	0.39	10	2.165	55	2.657	67.5	3.150	80
E090	3.54	90	0.26	6.5	3.94	100	3.15	80	0.79	20k6	1.57	40	0.39	10	2.81	71.5	3.48	88.5	4.17	106
E115	4.53	115	0.33	8.5	5.12	130	4.33	110	0.98	25k6	2.17	55	0.59	15	3.9	99	4.96	126	6.02	153

Series LE

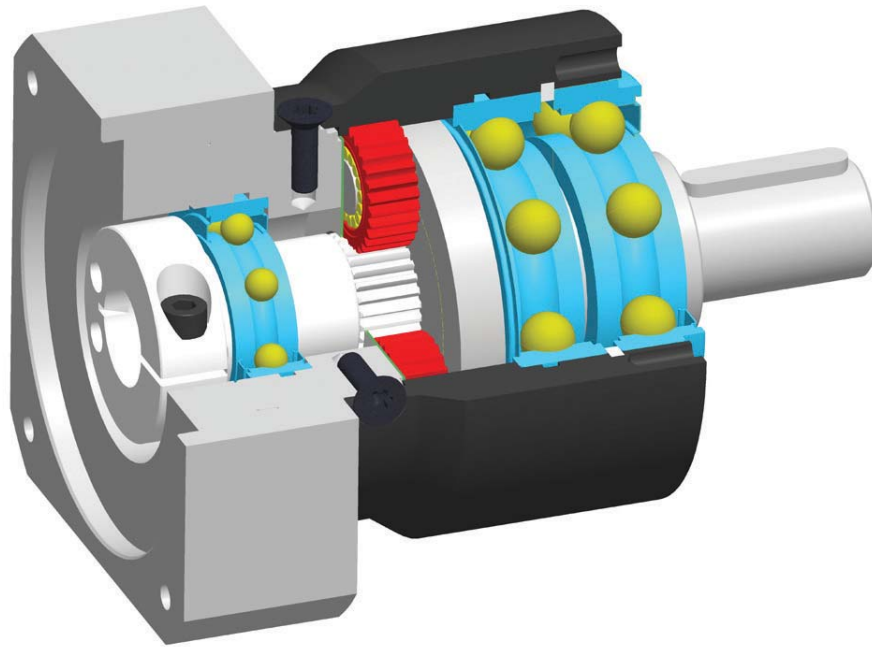

New to the Series E family, the Series LE maintains the same high quality honed gearing providing the highest torque densities in the market.

- Precision clamping system to eliminate motor shaft slipping.
- Precision honed gearing for lower noise at higher speeds.
- Integral output shaft and planet carrier
- Carbon steel and hardened honed ring gear integral to the housing. Providing low noise, minimum wear and consistent low backlash.
- Grease lubricated for life.

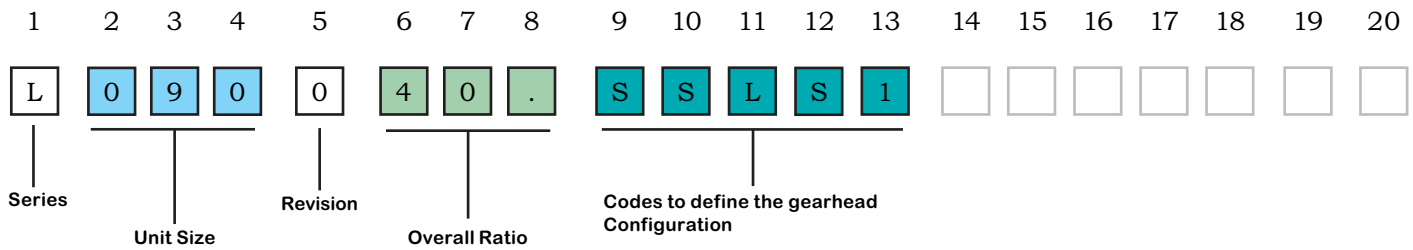

Step 1

Series of Gearhead

Code Position : 1

Example Code : L

Step 2

Size of Gearhead

Code Position : 2 3 4

Example Code : 0 9 0

Options:

0	5	0
0	7	0
0	9	0
1	2	0

Step 3

Revision Level

Code Position : 5

Example Code : 0

Step 4

Overall Ratio

Code Position : 6 7 8

Example Code : 4 0 .

Options:

Single Reduction			Double Reduction		
3	.	0	9	.	0
4	.	0	1	2	.
5	.	0	1	5	.
7	.	0	1	6	.
8	.	0	2	0	.
1	0	.	2	5	.
			3	2	.
			4	0	.
			6	4	.
			1	0	0



Step 5

Backlash Level

Code Position : 9

Example Code : S

Options : S-Standard Backlash

Step 6

Type of Unit

Code Position : 10

Example Code : S

Options: S - Fits Servo Motor

Step 7

Output Type

Code Position : 11

Example Code : L

Options: L - Type LE

Step 8

Motor Type

Code Position : 12

Example Code : S

Options: S - Fits a Servo Motor

Step 9

Assembly Position

Code Position : 13

Example Code : 1

Options: 1 - Single Extended Output

1 2 3 4 5 6 7 8 9 10 11 12 13 14 15 16 17 18 19 20

L 0 9 0 0 4 0 . S S L S 1 D H L D K G -

Step 10

Motor Shaft Length

Code Position : 14

Example Code : **D**

See Page 16 for motor shaft length code

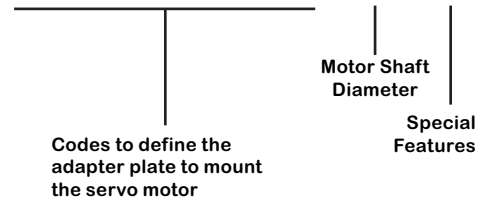
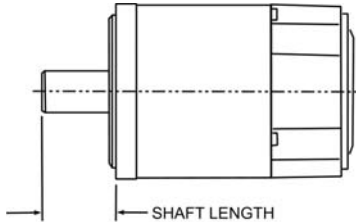

Step 11

Motor Flange Square

Code Position : 15

Example Code : **H**

See Page 16 for motor flange square code

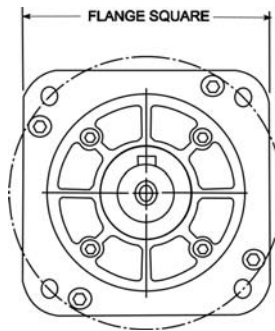

Step 14

Motor Bolt Hole Diameter

Code Position : 18

Example Code : **K**

See Page 16 for motor bolt hole diameter code

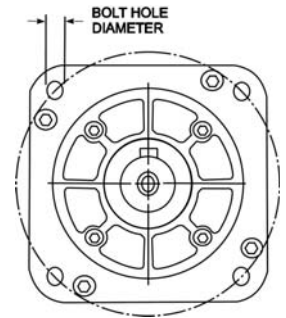

Step 12

Motor Pilot Diameter

Code Position : 16

Example Code : **L**

See Page 16 for motor pilot diameter code

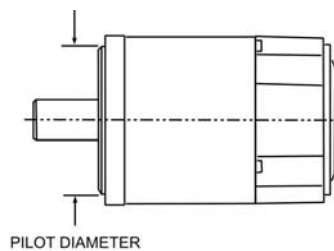

Step 15

Motor Shaft Diameter

Code Position : 19

Example Code : **G**

See Page 16 for motor shaft diameter code

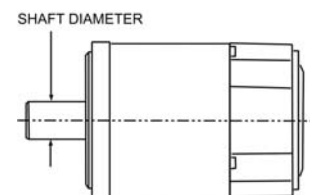

Step 13

Motor Bolt Circle Diameter

Code Position : 17

Example Code : **D**

See Page 16 for motor bolt circle diameter code

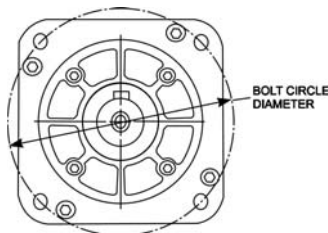

Step 16

Special Features

Code Position : 20

Example Code : **-**

Options:

- No special features
- S** Stainless steel paint
- W** White epoxy paint

LE50 SELECTIONS	COLUMN 14 ENTRY	SHAFT LENGTH									
		25									
		M									
	COLUMN 15 ENTRY	FLANGE SQUARE									
		40	60								
		M	P								
COLUMN 16 ENTRY	PILOT DIAMETER										
	20.02	30	38.1								
	S	T	A								
COLUMN 17 ENTRY	BOLT CIRCLE										
	46	46.7	66.68								
	V	W	C								
COLUMN 18 ENTRY	BOLT HOLE DIAMETER IN MOTOR FLANGE										
	3.2 - 3.6	4.3 - 4.8									
	J	K									
COLUMN 19 ENTRY	MOTOR SHAFT DIAMETER										
	4	.5	6	6.35	8						
	X	Y	Z	A	B						

LE70 SELECTIONS	COLUMN 14 ENTRY	SHAFT LENGTH									
		23	25	30	32	40					
		A	M	B	C	D					
	COLUMN 15 ENTRY	FLANGE SQUARE									
		60	70	80	90						
		P	A	B	C						
COLUMN 16 ENTRY	PILOT DIAMETER										
	30	38.1	40	50	60	70	73.07				
	T	A	B	C	D	E	F				
COLUMN 17 ENTRY	BOLT CIRCLE										
	46	63	65	66.68	70	75	80	90	95	98.43	
	V	A	B	C	D	E	F	G	H	J	
COLUMN 18 ENTRY	BOLT HOLE DIAMETER IN MOTOR FLANGE										
	4.5 - 5.2	5.3 - 6.3	6.4 - 8.3								
	A	B	C								
COLUMN 19 ENTRY	MOTOR SHAFT DIAMETER										
	6	6.35	8	9	9.525	10	11	12	12.7	14	
	Z	A	B	C	D	E	F	G	H	J	

LE90 SELECTIONS	COLUMN 14 ENTRY	SHAFT LENGTH									
		30	32	40	50	58					
		B	C	D	F	G					
	COLUMN 15 ENTRY	FLANGE SQUARE									
		80	90	100	115	120					
		B	C	D	E	F					
COLUMN 16 ENTRY	PILOT DIAMETER										
	38.1	40	50	60	70	73.07	80	95	110		
	A	B	C	D	E	F	G	H	J		
COLUMN 17 ENTRY	BOLT CIRCLE										
	66.68	70	75	80	90	95	98.43	100	115	130	145
	C	D	E	F	G	H	J	K	L	M	N
COLUMN 18 ENTRY	BOLT HOLE DIAMETER IN MOTOR FLANGE										
	4.5 - 5.2	5.3 - 6.3	6.4 - 8.3	8.4 - 10.3							
	A	B	C	D							
COLUMN 19 ENTRY	MOTOR SHAFT DIAMETER										
	9.525	10	11	12	12.7	14	16	19			
	D	E	F	G	H	J	K	L			

LE120 SELECTIONS	COLUMN 14 ENTRY	SHAFT LENGTH									
		40	45	50	58						
		D	E	F	G						
	COLUMN 15 ENTRY	FLANGE SQUARE									
		115	120	140							
		E	F	G							
COLUMN 16 ENTRY	PILOT DIAMETER										
	80	70	73.07	95	110	130					
	G	E	F	H	J	L					
COLUMN 17 ENTRY	BOLT CIRCLE										
	90	98.43	100	115	130	145	165				
	G	J	K	L	M	N	P				
COLUMN 18 ENTRY	BOLT HOLE DIAMETER IN MOTOR FLANGE										
	5.3 - 6.3	6.4 - 8.3	8.4 - 10.3	10.4 - 12.4							
	B	C	D	E							
COLUMN 19 ENTRY	MOTOR SHAFT DIAMETER										
	11	12.7	14	16	19	22	24				
	F	H	J	K	L	M	N				

OUTPUT TORQUE RATINGS

Ratios	Gear Stages		Output Torque by Gearhead Size							
			LE50		LE70		LE90		LE120	
			T _{2N}	T _{MAX}	T _{2N}	T _{MAX}	T _{2N}	T _{MAX}	T _{2N}	T _{MAX}
3	1	lb.In.	97	156	248	398	752	1204	1018	1628
		Nm	11	17.6	28	45	85	136	115	184
4	1	lb.In.	133	212	292	469	797	1274	1372	2195
		Nm	15	24	33	53	90	144	155	248
5	1	lb.In.	115	186	266	425	726	1159	1522	2434
		Nm	13	21	30	48	82	131	172	275
7	1	lb.In.	75	120	221	354	575	748	1195	1912
		Nm	8.5	13.6	25	40	65	84.5	135	216
8	1	lb.In.	53	89	159	257	443	708	1062	1699
		Nm	6	10	18	29	50	80	120	192
10	1	lb.In.	44	71	133	212	336	540	841	1345
		Nm	5	8	15	24	38	61	95	152
9	2	lb.In.	106	168	292	469	858	1372	1389	2221
		Nm	12	19	33	53	97	155	157	251
12	2	lb.In.	133	212	292	469	797	1274	1726	2761
		Nm	15	24	33	53	90	144	195	312
15	2	lb.In.	115	186	292	469	726	1159	1522	2434
		Nm	13	21	33	53	82	131	172	275
16	2	lb.In.	133	212	292	469	797	1274	1726	2761
		Nm	15	24	33	53	90	144	195	312
20	2	lb.In.	133	212	292	469	797	1274	1726	2761
		Nm	15	24	33	53	90	144	195	312
25	2	lb.In.	115	186	266	425	726	1159	1522	2434
		Nm	13	21	30	48	82	131	172	275
32	2	lb.In.	133	212	292	469	797	1274	1726	2761
		Nm	15	24	33	53	90	144	195	312
40	2	lb.In.	115	186	266	425	726	1159	1522	2434
		Nm	13	21	30	48	82	131	172	275
64	2	lb.In.	66	106	159	257	443	708	1062	1699
		Nm	7.5	12	18	29	50	80	120	192
100	2	lb.In.	44	71	133	212	336	540	841	1345
		Nm	5	8	15	24	38	61	95	152

T_{2N} = Continuous duty rated torque, at uniform load, 30000 hours L10 design life, at 100 rpm output shaft speed
 T_{MAX} = Maximum torque allowable for 30000 output shaft rotations

	Gear Stages		Size			
			LE50	LE70	LE90	LE120
Emergency Stop			$2 \times T_{2N}$			
Degree of Protection			IP54			
Maximum Radial Frmax Load for 20,000 hours		lbs.	179.8	236.0	427.1	562.0
		N	800	1050	1900	2500
Maximum Radial Frmax Load for 30,000 hours		lbs.	157.4	202.3	382.2	472.1
		N	700	900	1700	2100
Maximum Axial Famax Load for 20,000 hours		lbs.	224.8	303.5	449.6	899.2
		N	1000	1350	2000	4000
Maximum Axial Famax Load for 30,000 hours		lbs.	179.8	224.8	337.2	674.4
		N	800	1000	1500	3000
Efficiency	1	%	96			
	2	%	94			
Lifetime		Hours	20,000			
Lifetime at $T_{2N} \times 0.88$			30,000			
Weight	1	lbs.	1.54	3.30	6.60	16.50
		kg.	0.70	1.5	3.0	7.5
	2	lbs.	1.98	3.96	8.14	21.34
		kg.	0.90	1.8	3.7	9.7
Maximum motor weight	1, 2	lbs.	4.40	7.7	19.8	35.2
		kg.	2.00	3.5	9.0	16.0

Series LE

GEARHEAD INERTIA

	Ratios	Gear Stages		Size				
				LE50	LE70	LE90	LE120	
Inertia (at the input)	3	1	kgcm ²	0.031	0.157	0.82	2.87	
			lbinsec ²	0.274	1.389	7.257	25.400	
	4		kgcm ²	0.022	0.106	0.57	1.92	
			lbinsec ²	0.195	0.938	5.045	16.992	
	5		kgcm ²	0.019	0.086	0.48	1.60	
			lbinsec ²	0.168	0.761	4.248	14.160	
	7		kgcm ²	0.018	0.078	0.45	1.50	
			lbinsec ²	0.159	0.690	3.983	13.275	
	8		kgcm ²	0.017	0.068	0.40	1.35	
			lbinsec ²	0.150	0.602	3.540	11.948	
	10		kgcm ²	0.016	0.066	0.40	1.30	
			lbinsec ²	0.142	0.584	3.540	11.505	
	9		2	kgcm ²	0.030	0.133	0.75	2.65
				lbinsec ²	0.266	1.177	6.638	23.453
	12	kgcm ²		0.029	0.128	0.73	2.57	
		lbinsec ²		0.257	1.133	6.461	22.745	
	15	kgcm ²		0.023	0.078	0.71	2.54	
		lbinsec ²		0.204	0.690	6.284	22.479	
	16	kgcm ²		0.022	0.089	0.50	1.76	
		lbinsec ²		0.195	0.788	4.425	15.576	
	20	kgcm ²		0.019	0.076	0.44	1.50	
		lbinsec ²		0.168	0.673	3.894	13.275	
	25	kgcm ²		0.019	0.075	0.44	1.50	
		lbinsec ²		0.168	0.664	3.894	13.275	
	32	kgcm ²		0.017	0.064	0.39	1.30	
		lbinsec ²		0.150	0.566	3.452	11.505	
	40	kgcm ²	0.016	0.064	0.39	1.30		
		lbinsec ²	0.142	0.566	3.452	11.505		
64	kgcm ²	0.016	0.064	0.39	1.30			
	lbinsec ²	0.142	0.566	3.452	11.505			
100	kgcm ²	0.016	0.064	0.39	1.30			
	lbinsec ²	0.142	0.566	3.452	11.505			

	Gear Stages		Size			
			LE50	LE70	LE90	LE120
Backlash	1	arcmin.	<15	<12	<8	<8
	2	arcmin.	<19	<15	<12	<12
Torsional Stiffness (per arcminute)	1	lb.in./arcmin	8.9	20.4	53.1	106.2
		Nm/arcmin	1.0	2.3	6.0	12.0
	2	lb.in./arcmin	9.7	22.1	57.5	115.1
		Nm/arcmin	1.1	2.5	6.5	13.0
Running Noise		dB(A)	58	58	60	65
Max. input speed		RPM	18000	13000	7000	6500

	Ratio		Size			
			LE50	LE70	LE90	LE120
Maximum continuous input speed at 50% T_{2N} and continuous operation (>50% duty cycle or 20 minutes continuous run).	3	RPM	5000	4500	3200	2550
			5000	4500	3650	2700
			5000	4500	4000	3050
			5000	4500	4000	3500
			5000	4500	4000	3500
			5000	4500	4000	3400
			5000	4500	4000	3500
			5000	4500	4000	3500
			5000	4500	4000	3500
			5000	4500	4000	3500
			5000	4500	4000	3500
			5000	4500	4000	3500
			5000	4500	4000	3500
			5000	4500	4000	3500

	Ratio		Size			
			LE50	LE70	LE90	LE120
Maximum continuous input speed at 100% T_{2N} and continuous operation (>50% duty cycle or 20 minutes continuous run).	3	RPM	5000	3600	2300	2000
			5000	4100	2600	2000
			5000	4500	3200	2200
			5000	4500	4000	3150
			5000	4500	4000	3500
			5000	4500	3400	2600
			5000	4500	4000	3500
			5000	4500	4000	2650
			5000	4500	4000	3100
			5000	4500	4000	3050
			5000	4500	4000	3500
			5000	4500	4000	3500
			5000	4500	4000	3500
			5000	4500	4000	3500

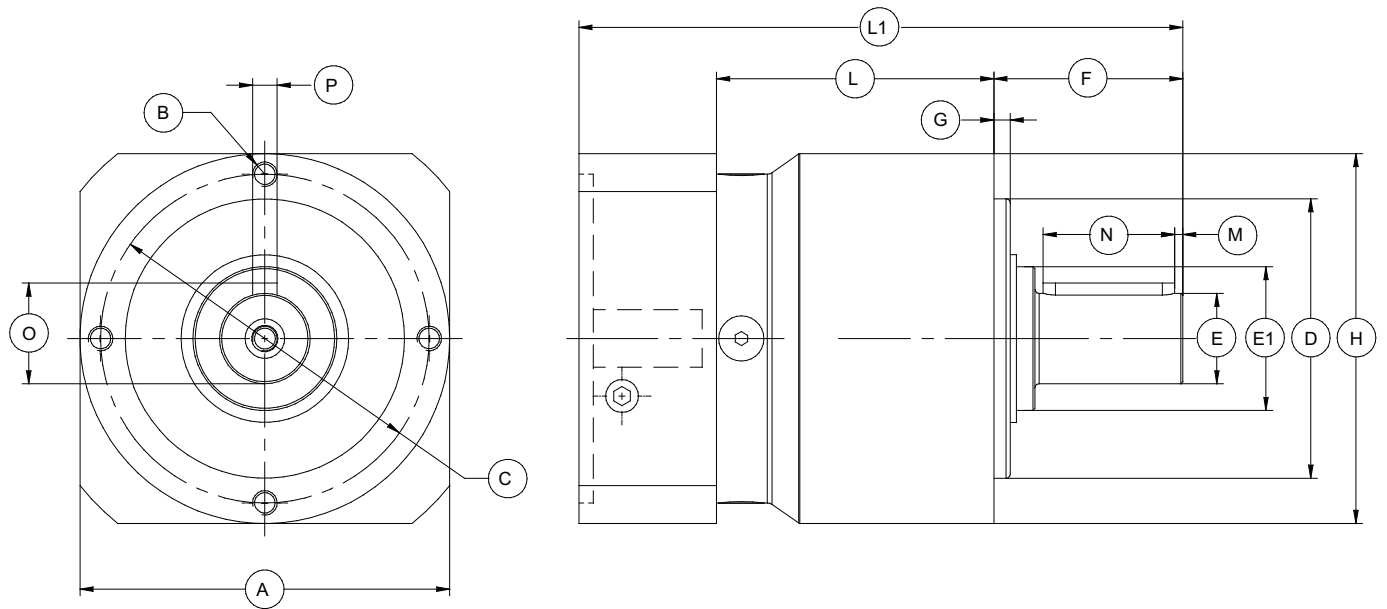

Standard Unit with C-FACE Output

Unit Size	A		B	C		D		E		E1		F		G		H	
	Input Flange Square			Mounting Hole Thread	Bolt Circle Diameter		Pilot Diameter h7 tolerance		Shaft Diameter k7 tolerance		Shaft Shoulder Diameter		Output Shaft Length from Flange		Pilot Depth		Housing Diameter
	Inch	mm	Inch		mm	Inch	mm	Inch	mm	Inch	mm	Inch	mm	Inch	mm	Inch	mm
LE50	1.575	40	M4 X 8	1.732	44	1.378	35	0.472	12	0.591	15	0.965	24.5	0.118	3	1.969	50
LE70	2.362	60	M5 X 8	2.441	62	2.047	52	0.630	16	1.181	30	1.417	36	0.118	3	2.756	70
LE90	3.543	90	M6 X 9	3.15	80	2.677	68	0.866	22	1.378	35	1.811	46	0.157	4	3.543	90
LE120	4.528	115	M8 X 16	4.252	108	3.543	90	1.260	32	1.969	50	2.677	68	0.197	5	4.724	120

Unit Size	L				L1				M		N		O		P	
	Body Length				Body Length				Distance from End of Shaft to Key		Keyway Length		Key & Shaft Height		Keyway Width	
	1 stage		2 stage		1 stage		2 stage									
	Inch	mm	Inch	mm	Inch	mm	Inch	mm	Inch	mm	Inch	mm	Inch	mm		
LE50	1.811	46	2.303	58.5	Gearhead length from motor plate to the end of the output shaft will vary depending on the motor selection. Please contact Cone Drive Engineering if length is critical to application to get exact gearhead length.				0.079	2	0.551	14	0.531	13.5	0.157	4
LE70	2.008	51	2.520	64					0.079	2	0.984	25	0.709	18	0.197	5
LE90	2.657	67.5	3.366	85.5					0.079	2	1.26	32	0.965	24.5	0.236	6
LE120	3.012	76.5	4.094	104					0.157	4	1.969	50	1.378	35	0.394	10

**"L" and "L1" dimensions may vary for longer than standard motor shaft dimensions.

Required Application Data

Motor Continuous Torque T_{cont}

Motor Peak Torque T_{peak}

Motor Rotor Inertia* J_{mot}

Load Inertia* J_{load}

Load Torque
(non-dynamic Frictional
and/or Gravity Load) T_{load}

Reduction Ratio **Ratio**

Calculated Data

Load torque reflected to input:

$$T_{input} = T_{load} / (\text{Ratio} \times \text{eff.})$$

Load inertia referred to input shaft:

$$J_{ref} = J_{load} / \text{Ratio}^2$$

Eff: Ratios $\leq 8:1 = .96$

Ratios $\geq 9.1 = .94$

data example:

$$T_{cont} = 10.9 \text{ Nm} \quad T_{peak} = 45.7 \text{ Nm} \quad J_{mot} = 1.0$$

$$J_{load} = 10 \quad T_{load} = 15 \text{ Nm} \quad \text{Ratio} = 3$$

*Any unit can be used for inertia as long as it
as used consistently.

for Cyclical Applications Using Motor Peak Torque

Step one

Calculate the inertia parameter: J_{par}

Step Two

Calculate the total gearhead required

Output torque: T_{output}

Step Three

Calculate service factor: **Sf**

Select reducer size and related output torque

T_{2N} from table on page #. For most applications the
calculated service factor should be greater than 1.0.

formula & applied calculation example:

$$J_{par} = J_{mot} / (J_{ref} + J_{mot})$$

$$J_{ref} = 10 / 3^2 = 1.11$$

$$J_{par} = 1 / (1.11 + 1) = .474$$

$$T_{output} = ((T_{peak} - T_{input}) \times (1 - J_{par}) + T_{input}) \times \text{Ratio} \times \text{Eff.}$$

$$Sf = T_{2N} / T_{output}$$

$$E115 \quad T_{2N} = 80 \text{ Nm}$$

$$Sf = 80 / 76.2 = 1.05$$

for Continous Applications Using Motor Continuous Torque

Calculate service factor : Sf

Select reducer size and related output torque

T_{2N} from table on page #. For most applications the
calculated service factor should be greater than 1.0.

formula & applied calculation example:

$$Sf = T_{2N} / (T_{cont} \times \text{Ratio} \times \text{Eff.})$$

$$E90 \quad T_{2N} = 40 \text{ Nm}$$

$$Sf = 40 / (10.9 \times 3 \times .96) = 1.27$$

Lubrication

Series E Planetary Servo Gearheads are lubricated with the synthetic grease type Kluberplex BEM 34/132. Under normal conditions the gearheads will require no lubrication service throughout the life of the unit. Series E gearheads are built for universal mounting, ready to mount in any position.

Installation

Motor on Gearhead:

1. Slide the motor shaft into the hollow bore input shaft until the gearhead and motor flanges are seated together.
2. Use the bolts provided to clamp the gearhead and motor flanges together. Tighten the bolts crosswise.
3. Tighten the clamping screw through the access slot in the gearhead flange to the following torque settings:

Torque Tightening					
Unit Size	E040	E060	E090	E115	E160
Lb. In.	18	40	80	150	350
Nm	2.0	4.5	9.5	16.5	40.0
Hex Key Size	2.5	3	4	5	6

Torque Tightening				
Unit Size	LE50	LE70	LE90	LE120
Lb. In.	18	40	80	150
Nm	2.0	4.5	9.5	16.5
Hex Key Size	2.5	3	4	5

4. Push the urethane plug provided into the access slot on the gearhead motor plate. This only applies to the E040.

5. Maximum Motor Weights

Motor Weight Maximum					
Unit Size	E040	E060	E090	E115	E160
Lbs.	4.5	7.75	20.0	35.0	110.0
Kg	2.0	3.5	9.0	16.0	50.0

Motor Weight Maximum				
Unit Size	LE50	LE70	LE90	LE120
Lbs.	4.5	7.75	20.0	35.0
Kg	2.0	3.5	9.0	16.0

Ancillary Components:

1. Couplings, sheaves and sprockets should be mounted on the shaft carefully. Do not pound or hammer them onto the shaft as this will damage bearings and seals.
2. Sprockets and sheaves should be mounted as close to the gearhead as possible and “V” belts and chains adjusted to the proper tension to keep bearing loading and shaft deflection to a minimum. Too much tension in belts and improper location of sheaves and sprockets will lead to excessive overhung load, bearing wear and shaft deflection. For specific information on overhung load capacity, shaft stress and bearing life, please contact us.

Start-Up

1. After the gear head has been properly mounted and aligned, it is ready for start-up.
2. Make sure driven machine is clear of all obstructions and all safety guards and covers are in place. If possible, turn motor shaft by hand to confirm drive system is operating freely and in correct direction of rotation.
3. Jog motor to confirm proper rotation.
4. Operate gearhead with minimum load for approximately 15 minutes (in both directions if applicable) to seat gears, bearings, and oil seals.

Maintenance

1. If a gearhead has to be repaired, contact us for detailed instruction, blueprints, parts list, etc. If necessary, field service is available.
2. If a gearhead is to be returned, contact us for instructions and a returned material authorization (RMA) number.
3. Please have model number information and serial number from the unit name plate recorded.



Cone Drive Family of Products



Model HP



AccuDrive



Gearsets



Specials



Cone Drive Operations, Inc
240 E. 12th Street,
Traverse City, MI. 49685

Sales: 1-888-994-2663
Sales Fax: 1-888-907-2663