



Double Enveloping Worm Gear Sets



Contents

<i>Cone Drive Gear Sets</i>	<i>173</i>
<i>Cone Drive Gear Sets - Tables of Backlash.....</i>	<i>174</i>
<i>Cone Drive - Standard Single and Double Extended Worms</i>	<i>175</i>
<i>Cone Drive - Standard Solid Shaft Gears</i>	<i>177</i>
<i>Cone Drive Standard Hub and Flange Type Gears.....</i>	<i>178</i>
<i>Cone Drive Standard Hollow Shaft, Ring & Flange Type Gears</i>	<i>179</i>
<i>Cone Drive Standard Gear Sets</i>	<i>180</i>
<i>Special Gear Sets</i>	<i>184</i>
<i>Cone Drive Gear Set Mountings</i>	<i>185</i>
<i>Cone Drive Standard Worm Mountings and Bearings.. ..</i>	<i>186</i>
<i>Cone Drive Standard Gearshaft Mountings and Bearings</i>	<i>191</i>
<i>Cone Drive Standard Gearshaft Mountings - Vertical.....</i>	<i>195</i>
<i>Cone Drive Standard Gearshaft Mountings and Bearings</i>	<i>196</i>
<i>Cone Drive Standard Solid Gearshafts.....</i>	<i>198</i>
<i>Cone Drive Standard Steeple Gearshaft Mountings and Bearings.....</i>	<i>201</i>
<i>Cone Drive Pump and Worm Mountings</i>	<i>204</i>

Cone Drive Gear Sets

Cone Drive gear sets are supplied in matched sets. Each set is inspected for tooth contact and smooth operation with the gears on the exact center distance, and with correct end position of worm and side position of gear. After inspection, an identifying set number is stamped on mating worm and gear. They should always be installed in sets, as marked.

The standardization of gear sets permits us to carry a quantity of stock "blanks," ready for final cutting to any of the ratios found in the tool charts on the following pages. Such standardization results in reduced costs as compared to "made-to-order" gear sets.

All standard Cone Drive gear sets have right hand-helix threads, however tooling is available for many left hand helix threads and other ratios in this section. For special center-distance and ratios see special gear sets in this section.

Where a Cone Drive gear set must be mounted in a specially designed housing, every effort should be made to follow the general design practice for Cone Drive reducers described in this catalog. If possible, standard mountings, such as those illustrated in this section should be used.

Where standard worm and gear blanks cannot be used, special designs can be developed by Cone Drive. Selection of the proper gear set depends upon the service characteristics under which the gears are to operate.

WHAT IS BACKLASH?

Backlash is defined as: the amount of movement at the pitch line of the gear when the output shaft is rotated, while holding the input shaft stationary. Bearings are set at zero end play for measurement, then adjusted afterwards according to loading, speed, and duty cycle.

Backlash should not be measured at the worm, because the amount of worm rotation with the gear locked is a function of ratio and helix angle.

A differentiation should be made between the terms "low backlash" and "precision" ...precision is a function of concentricity, worm and gear pitch line runout, gear tooth spacing error, and mounting runout. A precision gear set is required to produce uniform, consistent backlash and speed.

Cone Drive Gear Sets - Tables of Backlash

Gearset Backlash - (Standard Backlash)

Size	Center Distance Inches	Inches	Degrees	Arc minutes
15	1.5	0.008	0.39	23
20	2	0.008	0.29	17
25	2.5	0.008	0.23	14
30	3	0.008	0.19	11
35	3.5	0.009	0.18	11
40	4	0.009	0.16	10
50	5	0.01	0.14	9
60	6	0.012	0.14	9
70	7	0.013	0.13	8
80	8	0.014	0.12	7
100	10	0.017	0.12	7
120	12	0.02	0.12	7
150	15	0.025	0.12	7
180	18	0.025	0.09	6
220	22	0.03	0.09	6
240	24	0.035	0.09	6
280	28	0.035	0.09	6

Notes:

Nominal Backlash values in inches, degrees, and arcminutes for low backlash and standard backlash. Backlash in inches is measured at pitch line. Size 100 and up worm is mounted in a type TDO double locked up tapered roller bearing with a fixed spacer which can be ground to reduce end play for low speeds. Contact Cone Drive.

Gearset Backlash - (Low Backlash)

Size	Center Distance Inches	Inches	Degrees	Arc minutes
15	1.5	0.002	0.097	6
20	2	0.002	0.072	4
25	2.5	0.002	0.058	4
30	3	0.002	0.047	3
35	3.5	0.002	0.041	2
40	4	0.002	0.036	2
50	5	0.002	0.028	2
60	6	0.002	0.024	1
70	7	0.002	0.02	1
80	8	0.002	0.018	1
100	10	0.004	0.028	2
120	12	0.004	0.023	1
150	15	0.006	0.028	2
180	18	0.006	0.023	1
220	22	*	*	*
240	24	*	*	*
280	28	*	*	*

Cone Drive - Standard Single and Double Extended Worms Size 15 to 80

▽ O.D. VARIES WITH RATIO, SEE TOOL CHART.

*DIMENSIONS HELD EXACT IN MANUFACTURING.

DASH LINE INDICATES DOUBLE EXTENDED WORM.

**THESE DIMENSIONS MAY VARY TO SUIT RATIO SELECTED

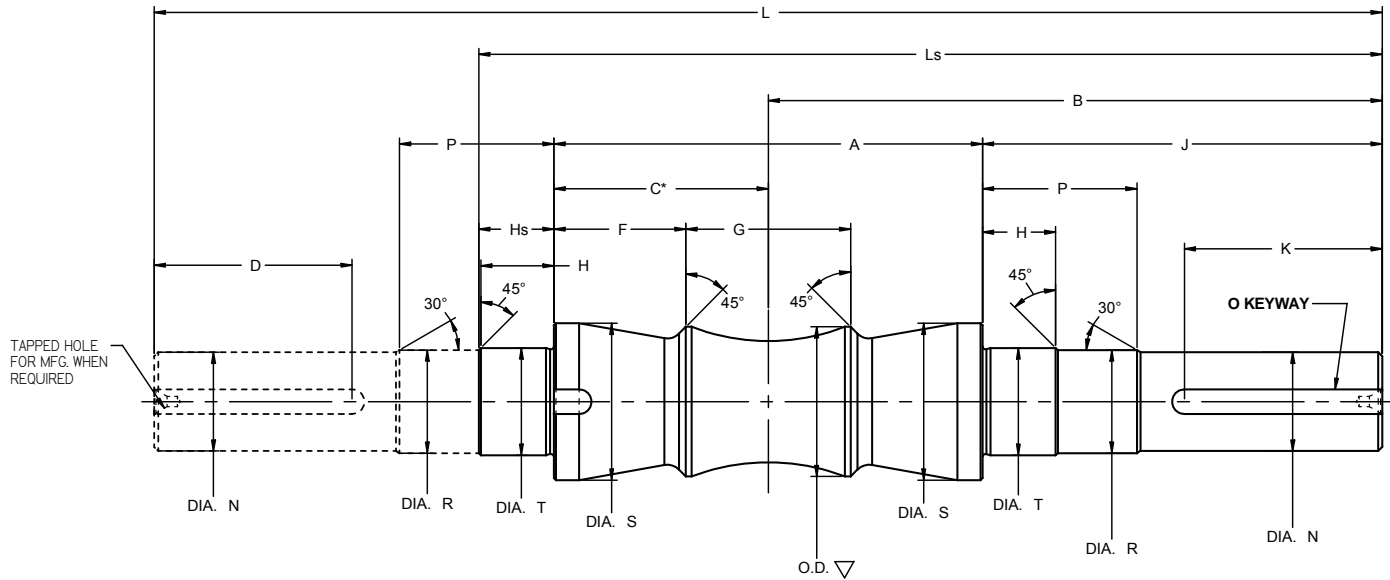

Size	C.D.	A	B	C*	D	F**	G**	H	J	K
15	1.500	2.000 ± .001	3.00	1.000	0.75	0.56	0.88	—	2.00	0.75
20	2.000	2.812 ± .001	4.59	1.406	1.06	0.78	1.25	0.83	3.19	1.06
25	2.500	4.187 ± .001	5.25	2.093	1.00	1.28	1.62	0.78	3.16	1.00
30	3.000	4.812 ± .001	6.68	2.406	1.75	1.40	2.00	0.90	4.28	1.75
35	3.500	5.500 ± .001	7.75	2.750	2.62	1.56	2.38	0.88	5.00	2.62
40F	4.000	6.500 ± .002	9.31	3.250	3.00	2.00	2.50	1.11	6.06	3.00
50F	5.000	8.500 ± .002	10.50	4.250	3.25	2.62	3.25	0.97	6.25	3.25
60F	6.000	9.000 ± .002	11.75	4.500	4.00	2.62	3.75	1.22	7.25	4.00
70F	7.000	9.000 ± .002	14.50	4.500	4.50	2.56	3.88	1.75	10.00	4.50
80F	8.000	10.250 ± .002	15.50	5.125	4.75	2.62	5.00	1.82	10.38	4.75

Size	L	N	O	P	R	S	T	HS	LS
15	6.00	0.625	3/16 x 3/32	0.97	—	1.00	0.7520	0.625	4.625
20	9.18	0.688	3/16 x 3/32	1.72	0.747	1.15	0.7520	0.846	6.840
25	10.50	0.750	3/16 x 3/32	1.72	0.875	1.38	0.9395	0.812	8.160
30	13.38	1.000	1/4 x 1/8	2.09	1.062	1.56	1.1270	0.932	10.030
35	15.50	1.188	1/4 x 1/8	1.96	1.250	1.84	1.3145	0.912	11.410
40F	18.62	1.500	3/8 x 3/16	2.34	1.563	2.37	1.6270	1.140	13.700
50F	21.00	1.500	3/8 x 3/16	2.25	1.563	2.75	1.7520	1.042	15.790
60F	23.50	1.750	3/8 x 3/16	2.53	1.813	3.00	1.8770	1.250	17.500
70F	29.00	1.875	1/2 x 1/4	2.82	2.125	3.81	2.7525	1.750	20.750
80F	31.00	2.000	1/2 x 1/4	2.94	2.125	4.125	3.0025	1.875	22.500

Cone Drive Standard Single & Double Extended Worms

Size 100 to 280

▽ O.D. VARIES WITH RATIO, SEE TOOL CHART.

*DIMENSIONS HELD EXACT IN MANUFACTURING.

DASH LINE INDICATES DOUBLE EXTENDED WORM.

**THESE DIMENSIONS MAY VARY TO SUIT RATIO SELECTED

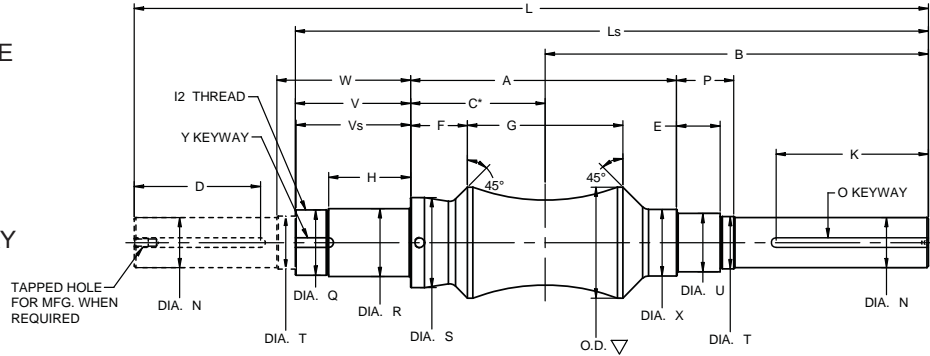

Size	C.D.	A	B	C*	D	E	F**	G**	H	J	K	L	N
100	10.000	12.875	19.25	6.625	4.25	1.53	3.560	6.12	4.38	13.00	5.00	38.50	2.375
120	12.000	14.812	22.5	7.625	4.5	1.81	3.880	7.50	6.25	15.31	5.88	45.75	3.000
150	15.000	19.500	26.25	9.750	5.5	2.00	5.120	9.25	7.12	16.50	8.50	54.12	3.500
180	18.000	20.750	30.12	10.375	7.5	2.50	4.750	11.25	7.12	19.75	10.00	61.62	4.000

Size	O	P	Q	R	S	T	U	V	W	X	Y	Single Extended	
												LS	VS
100	5/8 x 5/16	2.59	3.340 - .011	3.349 - .001	4.62	2.437	2.9536 - .0006	6.25	7.31	3.50	5/8 x 3/16	32.12	6.25
120	3/4 x 3/8	3.12	3.918 - .011	4.0025 - .001	5.75	3.125	3.3475 - .0008	8.5	9.68	4.00	3/4 x 7/32	38.62	8.50
150	7/8 x 7/16	—	4.325 - .011	4.5025 - .001	6.50	—	3.5443 - .0008	9.37	—	4.00	3/8 x 3/16	45.38	9.37
180	1" x 1/2	—	4.716 - .011	5.0025 - .001	7.00	—	4.1349 - .0008	9.88	—	4.75	3/8 x 3/16	50.38	9.88

▽ O.D. VARIES WITH RATIO, SEE TOOL CHART.

*DIMENSION HELD EXACT IN MANUFACTURING.

DASH LINE INDICATES DOUBLE EXTENDED WORM.

**THESE DIMENSIONS MAY VARY TO SUIT RATIO SELECTED

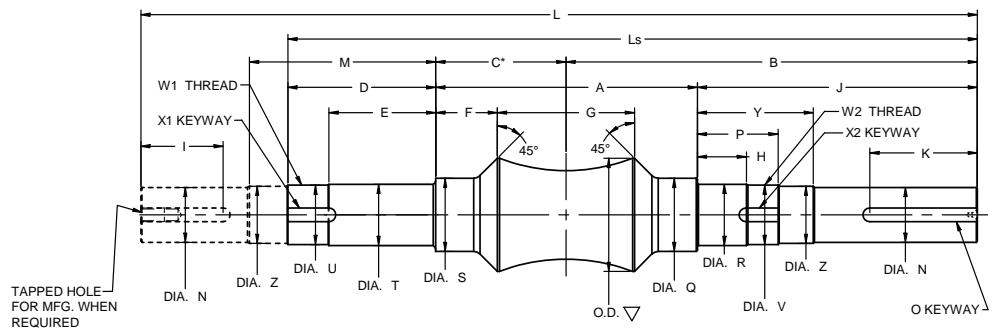

Size	C.D.	A	B	C*	D	E	F**	G**	H	I	J	K	L	M
220	21.837	24.000	34.50	12.125	10.38	7.38	5.15	14.00	3.88	9.50	22.62	10.00	71.50	-
240	24.000	26.375	40.00	13.750	10.12	7.12	5.75	16.00	5.06	9.75	27.38	10.00	80.00	15.12
280	28.000	33.375	46.00	17.375	13.50	10.00	8.38	18.00	5.50	9.00	30.00	13.00	94.00	18.25

Size	N	O	P	Q	R	S	T	Y	Z	Ls	Locknut Threads & Keyway Data					
											Diameter					
											U	V	W1	W2	X1	X2
220	4.500	1" x 1/2	5.15	6.00	5.2525	8.12	6.1275	—	—	57	5.888 - .011	4.716 - .011	12	12	5/8 x 7/32	3/8 x 3/16
240	5.000	1 1/4 x 7/16	6.50	7.00	5.8775	8.25	6.3775	11.38	5.375	63.88	6.284 - .015	5.497 - .011	8	12	5/8 x 5/16	5/8 x 1/4
280	6.000	1 1/2 x 1/2	7.25	8.25	7.0025	10.25	8.0025	12.00	6.25	76.88	7.847 - .015	6.659 - .015	8	8	7/8 x 5/16	3/4 x 5/16

Cone Drive - Standard Solid Shaft Gears Size 15 to 120

Size 15 thru 35

Size 40 thru 120

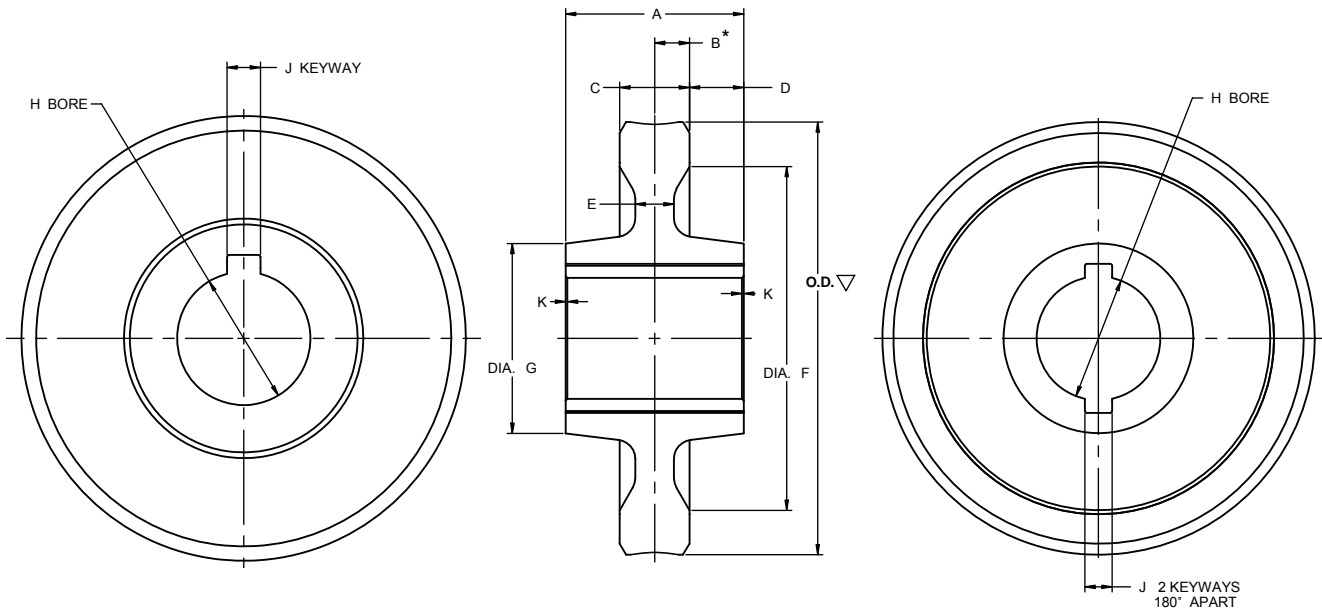

▽ O.D. VARIES WITH RATIO, SEE TOOL CHART.
 *DIMENSIONS HELD EXACT IN MANUFACTURING.

Note: Gear and hub construction will be one or more of several designs at Cone Drives option.

Note: Sets are matched with worm over, looking at worm from single extended end, the marked face of gear is to the left.

Size	C.D.	A	B*	C	D	E	Fmax.	G	H	J	K
15	1.500	2.000 ± .001	0.20	0.400	.80 ± .001	—	—	1.28	0.748	3/16 x 3/32	.03 x 45°
20	2.000	1.750 ± .001	0.281	0.5625	.594 ± .001	—	—	1.75	1.250	1/4 x 1/8	
25	2.500	1.750 ± .001	0.375	0.750	.500 ± .001	—	—	2.00	1.250	1/4 x 1/8	
30	3.000	2.625 ± .001	0.4375	0.875	.875 ± .001	0.50	4.00	2.62	1.625	3/8 x 3/16	
35	3.500	3.125 ± .001	0.5	1.000	1.062 ± .001	0.50	4.62	3.25	2.188	1/2 x 1/4	
40	4.000	3.625 ± .002	0.5625	1.125	1.250 ± .001	0.62	5.50	4.00	2.625	1/2 x 1/4	.06 x 45°
50	5.000	4.250 ± .002	0.6875	1.375	1.4375 ± .001	0.75	6.88	4.50	3.125	5/8 x 5/16	
60	6.000	5.000 ± .002	0.875	1.750	1.625 ± .001	0.88	8.38	5.50	3.625	3/4 x 3/8	
70	7.000	5.000 ± .005	0.875	1.750	1.625 ± .002	1.00	9.62	6.12	4.000	7/8 x 7/16	
80	8.000	5.750 ± .005	1.125	2.250	1.750 ± .002	1.25	11.09	6.12	4.000	7/8 x 7/16	
100	10.000	6.000 ± .005	1.375	2.750	1.625 ± .002	1.5	14.38	6.25	4.250	1 x 3/8	
120	12.000	6.750 ± .005	1.625	3.250	1.750 ± .002	1.75	17.25	9.00	6.125	1 1/4 x 7/16	

Cone Drive Standard Hub and Flange Type Gears

Size 150 to 280

Hub Type Spider & Gear Assembly

∇ O.D. VARIES WITH RATIO, SEE TOOL CHART.

*DIMENSIONS HELD EXACT IN MANUFACTURING.

Note: Sets are matched with worm over, looking at worm from single extended end, the marked face of gear is to the left.

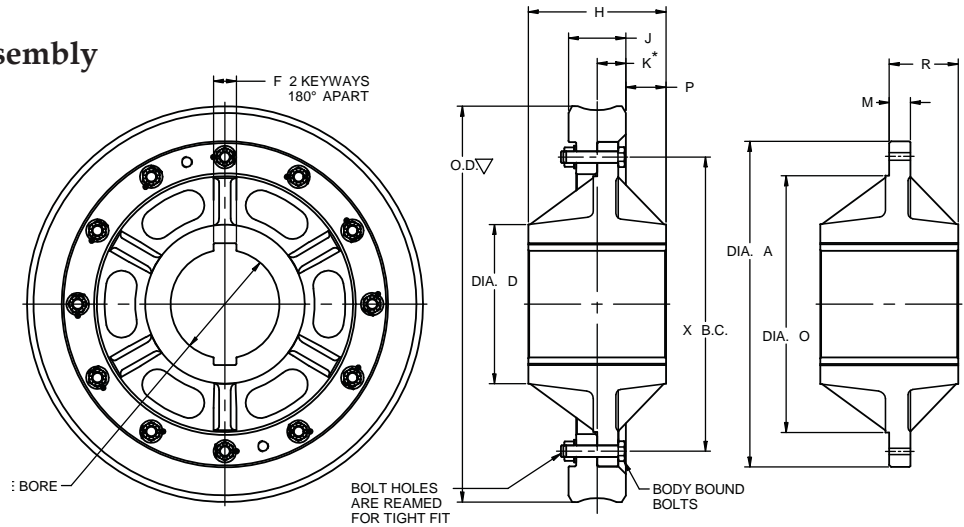

Size	C.D.	A	D	E	F	H	J	K*	M	O	P	R	X	Body Bound Bolts		For ratios up Thru 5:1 USE These Dimensions		
														NO.	SIZE	A	O	x
150	15.000	21.257	10.38	7.125	1 1/2 x 1/2	9.000	3.750	1.875	1.38	16.88	2.625	4.500	19.250	12	0.750	20.551	16.75	18.500
180	18.000	26.509	11.88	8.125	1 3/4 x 5/8	10.500	4.000	2.000	1.62	21.18	3.250	5.250	24.000	12	1.000	24.571	19.18	22.000
220	21.837	32.011	15.75	9.500	2 1/2 x 7/8	12.000	4.500	2.250	1.75	26.50	3.750	6.000	29.500	12	1.250	-	-	-
240	24.000	35.012	16.25	10.500	2 1/ x 7/8	14.000	5.000	2.500	2.00	28.75	4.500	7.000	32.000	18	1.250	31.762	25.5	28.750
280	28.000	41.014	20.00	13.250	3" x 1"	17.000	6.000	3.000	2.25	35.00	5.500	8.500	38.250	18	1.500			

Flange Type Gear

∇ O.D. VARIES WITH RATIO, SEE TOOL CHART.

*DIMENSIONS HELD EXACT IN MANUFACTURING.

Note: Sets are matched with worm over, looking at worm from single extended end, the marked face of gear is to the left.

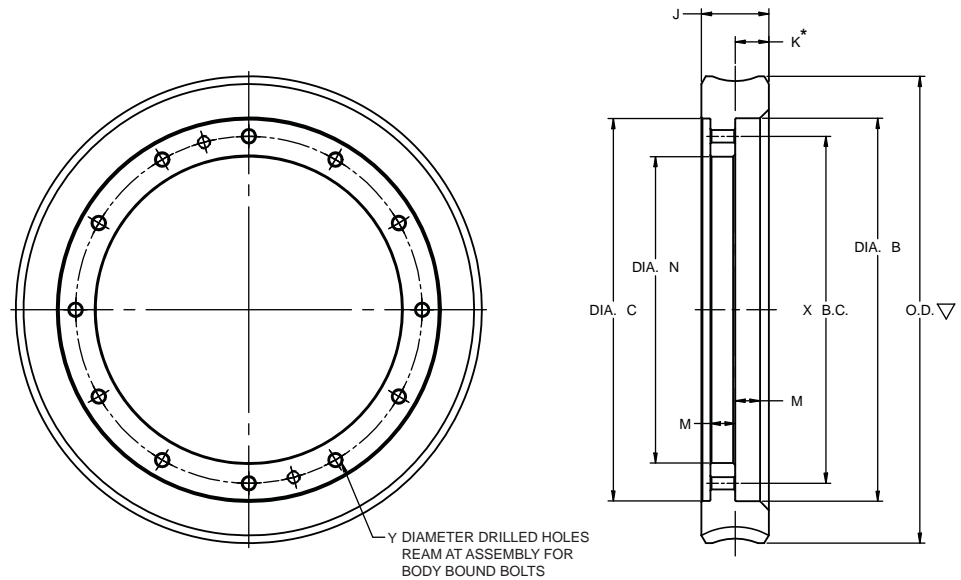

Size	C.D.	B	C	J	K*	M	N	X	Y	Bolts		For ratios up Thru 5:1 USE These Dimensions			
										NO.	SIZE	B	C	N	X
150	15.000	21.250 + .002	21.218	3.750	1.875	1.37	17.000	19.250	0.687	12	3/4	20.544	20.510	16.875	18.500
180	18.000	26.500 + .002	26.468	4.000	2.000	1.62	21.375	24.000	0.968	12	1"	24.562	24.530	19.375	22.000
220	21.837	32.000 + .003	31.968	4.500	2.250	1.75	27.000	29.500	1.218	12	1 1/4	—	—	—	—
240	24.000	35.000 + .003	34.968	5.000	2.500	2.00	29.000	32.000	1.218	18	1 1/4	31.750	31.720	25.750	28.750
280	28.000	41.000 + .004	42.000	6.000	3.000	2.25	35.500	38.250	1.468	18	1 1/2	—	—	—	—

Cone Drive Standard Hollow Shaft, Ring & Flange Type Gears

Hollow Shaft

Size 20 to 80

▽ O.D. VARIES WITH RATIO, SEE TOOL CHART.

*DIMENSIONS HELD EXACT IN MANUFACTURING.

Note: Sets are matched with worm over, looking at worm from single extended end, the marked face of gear is to the left.

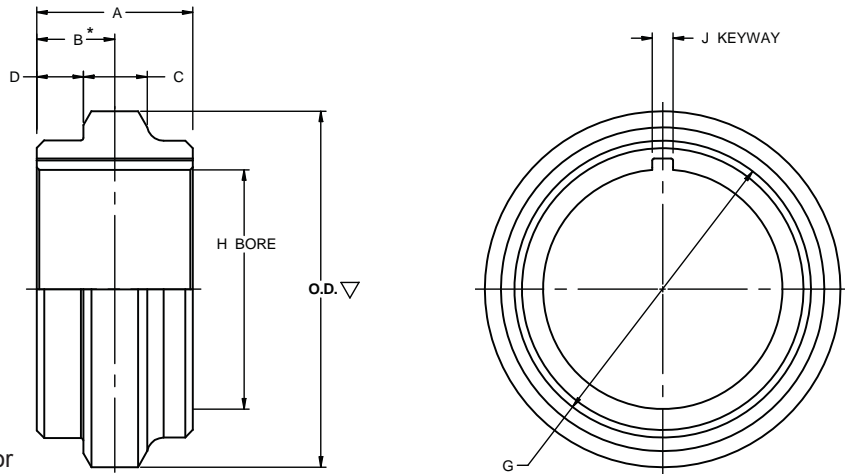

Note: Gear and Hub construction will be one or more of several designs at Cone Drives option.

Size	C.D.	A	B*	C	D	G	H	J
20	2.000	1.875 ± .001	0.9375	0.594	0.641	2.62	2.125	1/4 x 1/8
25	2.500	1.875 ± .001	0.9375	0.781	0.547	3.37	2.875	1/4 x 1/8
30	3.000	3.375 ± .001	1.6875	0.906	1.234	4.06	3.4375	3/8 x 3/16
35	3.500	4.000 ± .001	2.000	1.031	1.484	5.06	3.875	3/8 x 3/16
40	4.000	3.000 ± .002	1.500	1.187	0.906	5.62	4.375	5/8 x 5/16
50	5.000	4.000 ± .002	2.000	1.437	1.281	6.75	5.125	5/8 x 5/16
60	6.000	5.000 ± .002	2.500	1.812	1.593	8.12	6.000	3/4 x 3/8
70	7.000	5.000 ± .002	2.500	1.750	1.625	9.50	7.375	1 x 1/2
80	8.000	5.000 ± .002	2.500	2.250	1.375	9.62	7.375	1 x 1/2

Ring Type Size 70 to 120

▽ O.D. VARIES WITH RATIO, SEE TOOL CHART.

*DIMENSIONS HELD EXACT IN MANUFACTURING.

Note: Sets are matched with worm over, looking at worm from single extended end, the marked face of gear is to the left.

These blanks are stocked and can be cut to any standard ratio desired.

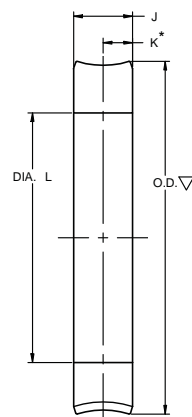

Flange Type Size 40 to 120

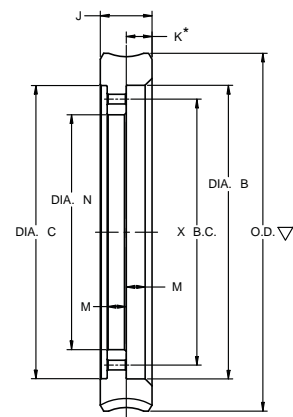

Y DIAMETER DRILLED HOLES REAM AT ASSEMBLY FOR BODY BOUND BOLTS

Size	C.D.	B	C	J	K*	L	M	N	X	Y	Bolts	
											No.	SIZE
40	4.000	5.375 + .001	5.343	1.125	0.5625	—	0.438	4.000	4.750	11/32	6	3/8
50	5.000	6.500 + .001	6.468	1.375	0.6875	—	0.500	4.562	5.500	13/32	6	7/16
60	6.000	7.934 + .001	7.906	1.750	0.875	—	0.625	5.625	6.750	15/32	8	1/2
70	7.000	9.000 + .001	8.968	1.750	0.875	9.250	0.750	6.000	7.500	19/32	8	5/8
80	8.000	10.750 + .002	10.718	2.250	1.125	10.625	0.750	7.750	9.250	19/32	8	5/8
100	10.000	13.500 + .002	13.468	2.750	1.375	13.375	0.875	10.000	11.750	11/16	12	3/4
120	12.000	16.500 + .002	16.468	3.250	1.625	16.125	1.250	12.750	14.625	11/16	12	3/4

Cone Drive Standard Gear Sets - Right Hand Tool Charts & Horsepower Ratings

C.D	TOOL CHART						AGMA MECHANICAL HORSEPOWER RATINGS									
	Ratio	Tool Number	GEAR		WORM		INPUT MECHANICAL H.P. RATINGS - 1.0 SERVICE FACTOR									
			Pitch Dia.	Outside Dia.	Pitch Dia.	Outside Dia.	WORM SPEEDS									
	100	200	300	580	720	870	1150	1750	2400	3000						
Size 15	5:1	71505	2.368	2.495	.632	.870	0.20	0.37	0.53	0.95	1.13	1.32	1.62	2.10	2.49	2.80
	10:1	71510	2.364	2.495	.636	.870	0.13	0.24	0.34	0.60	0.73	0.85	1.06	1.40	1.67	1.89
	15:1	71515	2.368	2.495	.632	.870	0.09	0.17	0.24	0.42	0.51	0.60	0.74	0.99	1.18	1.33
	20:1	71520	2.342	2.448	.658	.870	0.07	0.13	0.18	0.32	0.39	0.46	0.57	0.76	0.91	1.03
	30:1	71530	2.371	2.495	.629	.870	0.05	0.09	0.12	0.22	0.26	0.31	0.38	0.51	0.62	0.70
	40:1	71540	2.343	2.448	.657	.870	0.03	0.06	0.09	0.16	0.20	0.23	0.29	0.39	0.45	0.50
	50:1	71550	2.326	2.424	.674	.870	0.03	0.05	0.07	0.13	0.16	0.19	0.23	0.31	0.37	0.42
	60:1	71560	2.315	2.424	.685	.870	0.02	0.04	0.06	0.11	0.13	0.16	0.19	0.26	0.30	0.34
Size 20*	5:1	7205	3.170	3.350	.830	1.156	0.40	0.73	1.04	1.83	2.18	2.51	3.02	3.81	4.51	5.09
	10:1	7210	3.200	3.380	.800	1.156	0.25	0.47	0.66	1.18	1.40	1.62	1.98	2.52	2.99	3.38
	15:1	7215	3.200	3.380	.800	1.156	0.18	0.33	0.47	0.83	0.99	1.15	1.40	1.79	2.13	2.39
	20:1	7220	3.170	3.350	.830	1.156	0.13	0.25	0.36	0.63	0.76	0.88	1.07	1.38	1.63	1.84
	25:1	7225	3.220	3.420	.780	1.156	0.11	0.20	0.29	0.51	0.61	0.71	0.87	1.11	1.32	1.48
	30:1	7230	3.200	3.380	.800	1.156	0.09	0.17	0.24	0.43	0.51	0.59	0.73	0.93	1.11	1.25
	40:1	7240	3.170	3.350	.830	1.156	0.07	0.13	0.18	0.32	0.38	0.45	0.55	0.70	0.83	0.94
	50:1	7250	3.150	3.320	.850	1.156	0.05	0.10	0.15	0.26	0.31	0.36	0.44	0.56	0.67	0.75
Size 25*	5:1	72505	3.930	4.170	1.070	1.500	0.78	1.43	2.04	3.52	4.13	4.68	5.48	6.87	8.06	9.00
	10:1	72510	3.980	4.230	1.020	1.500	0.49	0.91	1.30	2.26	2.67	3.05	3.62	4.54	5.36	6.00
	15:1	72515	3.980	4.230	1.020	1.500	0.35	0.64	0.91	1.59	1.89	2.16	2.57	3.22	3.81	4.26
	20:1	72520	3.930	4.170	1.070	1.500	0.27	0.49	0.70	1.22	1.44	1.65	1.97	2.48	2.93	3.30
	25:1	72525	4.000	4.270	1.000	1.500	0.21	0.40	0.56	0.98	1.16	1.33	1.59	2.00	2.36	2.64
	30:1	72530	3.980	4.230	1.020	1.500	0.18	0.33	0.47	0.82	0.98	1.12	1.33	1.68	1.98	2.21
	40:1	72540	3.930	4.170	1.070	1.500	0.13	0.25	0.35	0.62	0.73	0.84	1.00	1.26	1.49	1.67
	50:1	72550	3.890	4.080	1.110	1.500	0.11	0.20	0.28	0.50	0.59	0.68	0.81	1.01	1.20	1.34
Size 30*	5:1	7305	4.700	4.990	1.300	1.810	1.38	2.53	3.60	6.05	6.99	7.79	9.06	11.3	13.1	14.3
	10:1	7310	4.850	5.150	1.150	1.700	0.88	1.62	2.31	3.97	4.65	5.26	6.16	7.72	9.05	10.1
	15:1	7315	4.850	5.150	1.150	1.700	0.62	1.14	1.62	2.80	3.29	3.74	4.38	5.49	6.45	7.16
	20:1	7320	4.800	5.050	1.200	1.700	0.47	0.87	1.24	2.15	2.52	2.87	3.37	4.22	4.97	5.52
	25:1	7325	4.770	4.990	1.230	1.700	0.38	0.70	1.00	1.73	2.04	2.31	2.72	3.41	4.01	4.45
	30:1	7330	4.850	5.150	1.150	1.700	0.32	0.59	0.84	1.45	1.71	1.94	2.28	2.86	3.36	3.74
	40:1	7340	4.800	5.050	1.200	1.700	0.24	0.44	0.63	1.09	1.28	1.46	1.72	2.15	2.53	2.81
	50:1	7350	4.770	4.990	1.230	1.700	0.19	0.36	0.51	0.88	1.03	1.17	1.38	1.73	2.03	2.26
Size 35*	5:1	73505	5.480	5.800	1.520	2.130	2.55	4.67	6.60	10.8	12.3	13.7	15.9	19.7	22.6	24.2
	10:1	73510	5.630	5.980	1.370	2.040	1.63	2.98	4.24	7.14	8.27	9.21	10.7	13.4	15.6	17.0
	15:1	73515	5.630	5.980	1.370	2.040	1.14	2.10	2.99	5.05	5.85	6.54	7.62	9.53	11.1	12.2
	20:1	73520	5.570	5.900	1.430	2.040	0.88	1.60	2.28	3.87	4.49	5.03	5.86	7.33	8.56	9.38
	25:1	73525	5.530	5.800	1.470	2.040	0.71	1.29	1.84	3.13	3.62	4.06	4.73	5.92	6.91	7.59
	30:1	73530	5.630	5.980	1.370	2.040	0.59	1.08	1.54	2.62	3.04	3.40	3.96	4.96	5.80	6.36
	40:1	73540	5.570	5.900	1.430	2.040	0.44	0.82	1.16	1.97	2.29	2.56	2.99	3.74	4.37	4.80
	50:1	73550	5.530	5.800	1.470	2.040	0.36	0.65	0.93	1.58	1.83	2.06	2.40	3.00	3.51	3.85
60:1	73560	5.500	5.760	1.500	2.040	0.30	0.55	0.78	1.32	1.53	1.72	2.00	2.51	2.93	3.21	

*No tooling charges on 2" - 3.5" c.d

Cone Drive Standard Gear Sets - Right Hand Tool Charts & Horsepower Ratings

C.D	TOOL CHART						AGMA MECHANICAL HORSEPOWER RATINGS									
	Ratio	Tool Number	GEAR		WORM		INPUT MECHANICAL H.P. RATINGS - 1.0 SERVICE FACTOR									
			Pitch Dia.	Outside Dia.	Pitch Dia.	Outside Dia.	WORM SPEEDS									
							100	200	300	580	720	870	1150	1750	2400	3000
Size 40*	5:1	7405	6.270	6.680	1.730	2.400	3.66	6.70	9.40	15.0	16.9	18.7	21.7	26.7	29.8	32.4
	10:1	7410	6.450	6.840	1.550	2.270	2.35	4.29	6.09	10.0	11.5	12.7	14.8	18.4	21.2	22.7
	15:1	7415	6.450	6.840	1.550	2.270	1.65	3.02	4.29	7.11	8.15	9.06	10.5	13.1	15.1	16.2
	20:1	7420	6.400	6.740	1.600	2.270	1.26	2.31	3.28	5.45	6.26	6.96	8.09	10.1	11.6	12.5
	25:1	7425	6.340	6.680	1.660	2.270	1.02	1.86	2.65	4.40	5.05	5.62	6.53	8.13	9.40	10.2
	30:1	7430	6.450	6.840	1.550	2.270	0.85	1.56	2.22	3.69	4.24	4.71	5.48	6.82	7.88	8.50
	40:1	7440	6.400	6.740	1.600	2.270	0.64	1.17	1.67	2.78	3.19	3.55	4.12	5.14	5.94	6.42
	50:1	7450	6.340	6.680	1.660	2.270	0.51	0.94	1.34	2.23	2.56	2.85	3.31	4.12	4.77	5.15
	60:1	7460	6.310	6.620	1.690	2.270	0.43	0.79	1.12	1.86	2.14	2.38	2.76	3.44	3.98	4.30
Size 50*	5:1	7505	7.840	8.280	2.160	3.000	7.21	13.2	18.2	27.6	31.0	34.3	39.6	47.4	52.6	59.2
	10:1	7510	8.090	8.560	1.910	2.850	4.63	8.46	11.8	18.8	21.1	23.4	27.2	33.3	37.1	40.2
	15:1	7515	8.090	8.560	1.910	2.850	3.25	5.96	8.36	13.3	15.0	16.7	19.3	23.8	26.5	28.7
	20:1	7520	8.020	8.420	1.980	2.850	2.49	4.56	6.40	10.2	11.6	12.8	14.9	18.3	20.5	22.1
	25:1	7525	7.950	8.280	2.050	2.850	2.01	3.67	5.16	8.27	9.34	10.3	12.0	14.8	16.6	17.9
	30:1	7530	8.090	8.560	1.910	2.850	1.68	3.08	4.32	6.93	7.83	8.67	10.1	12.4	13.9	15.1
	40:1	7540	8.020	8.420	1.980	2.850	1.27	2.32	3.25	5.22	5.90	6.53	7.58	9.34	10.5	11.3
	50:1	7550	7.950	8.280	2.050	2.850	1.02	1.86	2.61	4.19	4.73	5.24	6.09	7.50	8.41	9.09
	60:1	7560	7.920	8.280	2.080	2.850	0.85	1.55	2.18	3.50	3.95	4.37	5.08	6.26	7.02	7.58
Size 60*	5:1	7605	9.410	9.975	2.590	3.437	11.1	21.0	27.3	40.4	45.3	50.1	57.5	66.8	75.0	81.2
	10:1	7610	9.580	10.200	2.420	3.437	7.08	12.9	17.8	27.1	30.4	33.7	38.8	46.4	51.6	56.2
	15:1	7615	9.700	10.310	2.300	3.437	4.98	9.10	12.6	19.2	21.6	23.9	27.6	33.2	36.8	40.0
	20:1	7620	9.580	10.200	2.420	3.437	3.81	6.96	9.64	14.8	16.6	18.4	21.2	25.6	28.4	31.0
	25:1	7625	9.540	10.100	2.460	3.437	3.07	5.61	7.78	11.9	13.4	14.9	17.2	20.7	22.9	24.9
	30:1	7630	9.700	10.310	2.300	3.437	2.57	4.70	6.52	10.0	11.3	12.5	14.4	17.4	19.2	20.9
	40:1	7640	9.580	10.200	2.420	3.437	1.94	3.54	4.90	7.54	8.47	9.38	10.8	13.1	14.5	15.7
	50:1	7650	9.540	10.100	2.460	3.437	1.55	2.84	3.93	6.05	6.80	7.53	8.70	10.5	11.6	12.7
	60:1	7660	9.470	9.975	2.530	3.437	1.30	2.37	3.28	5.05	5.68	6.29	7.26	8.79	9.72	10.6
70:1	7670	9.450	9.975	2.550	3.313	1.11	2.03	2.82	4.34	4.87	5.40	6.23	7.55	8.35	9.08	

All ratings to the right of heavy line require force feed lubrication.
 *No tooling charges on 4" - 6" c.d.

Cone Drive Standard Gear Sets - Right Hand Tool Charts & Horsepower Ratings

C.D	TOOL CHART						AGMA MECHANICAL HORSEPOWER RATINGS									
	Ratio	Tool Number	GEAR		WORM		INPUT MECHANICAL H.P. RATINGS - 1.0 SERVICE FACTOR									
			Pitch Dia.	Outside Dia.	Pitch Dia.	Outside Dia.	WORM SPEEDS									
							100	200	300	580	720	870	1150	1750	2400	3000
Size 70	5:1	7705	10.980	11.600	3.020	4.000	17.5	31.1	41.6	60.0	67.3	73.9	83.6	96.4	108	116
	10:1	7710	11.330	11.930	2.670	3.687	11.2	20.3	27.7	41.1	46.2	51.2	58.7	68.4	76.9	83.5
	15:1	7715	11.270	11.810	2.730	3.687	7.88	14.3	19.6	29.3	32.9	36.5	41.9	49.2	55.1	59.9
	20:1	7720	11.330	11.930	2.670	3.687	6.03	11.0	15.0	22.5	25.3	28.0	32.2	37.9	42.4	46.1
	25:1	7725	11.250	11.810	2.750	3.687	4.86	8.83	12.2	18.2	20.5	22.6	26.0	30.7	34.3	37.1
	30:1	7730	11.190	11.700	2.810	3.687	4.07	7.40	10.2	15.3	17.2	19.0	21.8	25.8	28.8	31.3
	40:1	7740	11.330	11.930	2.670	3.687	3.06	5.57	7.66	11.5	12.9	14.3	16.4	19.4	21.7	23.5
	50:1	7750	11.250	11.810	2.750	3.687	2.46	4.47	6.15	9.23	10.4	11.5	13.2	15.6	17.4	18.9
	60:1	7760	11.190	11.700	2.810	3.687	2.05	3.73	5.13	7.71	8.66	9.58	11.0	13.0	14.6	15.8
	70:1	7770	11.150	11.600	2.850	3.687	1.76	3.20	4.41	6.62	7.43	8.23	9.46	11.2	12.5	13.5
Size 80	5:1	7805	12.550	13.210	3.450	4.625	25.9	45.5	59.6	85.3	95.2	104	116	134	150	158
	10:1	7810	13.200	13.960	2.800	4.125	16.7	30.1	40.9	60.0	67.4	74.4	85.1	98.7	111	120
	15:1	7815	13.060	13.750	2.940	4.125	11.8	21.3	29.0	42.9	48.2	53.2	61.2	71.0	79.8	86.0
	20:1	7820	13.200	13.960	2.800	4.125	9.00	16.3	22.2	33.0	37.0	40.9	47.0	54.7	61.4	66.6
	25:1	7825	13.100	13.750	2.900	4.125	7.26	13.1	18.0	26.6	29.9	33.1	38.0	44.3	49.7	54.0
	30:1	7830	13.060	13.750	2.940	4.125	6.08	11.0	15.1	22.4	25.1	27.8	31.9	37.2	41.7	45.3
	40:1	7840	13.200	13.960	2.800	4.125	4.58	8.29	11.3	16.8	18.9	20.9	24.0	28.0	31.4	34.1
	50:1	7850	13.100	13.750	2.900	4.125	3.67	6.65	9.10	13.5	15.2	16.8	19.3	22.5	25.3	27.3
	60:1	7860	13.090	13.750	2.910	4.125	3.07	5.55	7.59	11.3	12.7	14.0	16.1	18.8	21.1	22.8
	70:1	7870	13.040	13.750	2.960	3.960	2.63	4.77	6.52	9.69	10.9	12.0	13.8	16.1	18.1	19.6

All ratings to the right of heavy line require force feed lubrication.

Cone Drive Standard Gear Sets - Right Hand Tool Charts & Horsepower Ratings

C.D	TOOL CHART						AGMA MECHANICAL HORSEPOWER RATINGS								
	Ratio	Tool Number	GEAR		WORM		INPUT MECHANICAL H.P. RATINGS - 1.0 SERVICE FACTOR								
			Pitch Dia.	Outside Dia.	Pitch Dia.	Outside Dia.	WORM SPEEDS								
							100	200	300	580	720	870	1150	1750	2400
Size 100	5:1	8005	15.700	16.500	4.300	5.600	48.5	82.3	105	148	164	178	194	226	245
	10:1	8010	16.400	17.250	3.600	5.062	31.4	55.5	73.2	105	117	129	144	166	186
	15:1	8015	16.400	17.250	3.600	5.062	22.1	39.2	52.1	74.8	83.7	91.9	104	119	133
	20:1	8020	16.450	17.350	3.550	5.062	16.9	30.1	40.0	57.5	64.4	70.7	79.8	91.8	103
	25:1	8025	16.400	17.250	3.600	5.062	13.6	24.3	32.3	46.5	52.1	57.2	64.6	74.3	83.3
	30:1	8030	16.300	17.050	3.700	5.062	11.4	20.3	27.1	39.0	43.7	48.0	54.2	62.4	70.0
	40:1	8040	16.450	17.250	3.550	5.062	8.60	15.3	20.4	29.4	32.9	36.1	40.9	47.0	52.7
	50:1	8050	16.400	17.250	3.600	5.062	6.90	12.3	16.4	23.6	26.4	29.0	32.8	37.8	42.3
	60:1	8060	16.330	17.050	3.670	5.062	5.76	10.3	13.7	19.7	22.1	24.2	27.4	31.6	35.4
	70:1	8070	16.280	17.050	3.720	5.000	4.94	8.80	11.7	16.9	18.9	20.8	23.5	27.1	30.4
Size 120	5:1	8205	18.820	19.750	5.180	6.750	81.3	134	167	235	257	271	300	346	366
	10:1	8210	19.700	20.600	4.300	6.187	53.2	91.8	118	167	186	202	221	258	283
	15:1	8215	19.700	20.600	4.300	6.187	37.5	65.0	83.9	119	133	145	159	185	205
	20:1	8220	19.840	20.880	4.160	6.187	28.7	49.8	64.4	91.9	102	111	122	143	158
	25:1	8225	19.700	20.600	4.300	6.187	23.1	40.2	52.1	74.3	82.7	90.1	99.1	115	128
	30:1	8230	19.610	20.420	4.390	6.187	19.4	33.7	43.7	62.4	69.4	75.7	83.2	97.0	108
	40:1	8240	19.840	20.880	4.160	6.187	14.6	25.4	32.9	47.0	52.2	57.0	62.7	73.0	81.1
	50:1	8250	19.700	20.600	4.300	6.187	11.7	20.4	26.4	37.7	41.9	45.8	50.4	58.7	65.2
	60:1	8260	19.640	20.420	4.360	6.187	9.77	17.0	22.1	31.5	35.0	38.2	42.1	49.0	54.4
	70:1	8270	19.590	20.420	4.410	6.000	8.39	14.6	18.9	27.0	30.1	32.8	36.1	42.1	46.7
Size 150	5:1	8505	23.600	24.750	6.400	8.625	149	233	290	396	423	453	501	554	601
	10:1	8510	24.900	26.100	5.100	7.320	99.3	166	208	293	322	343	378	438	467
	15:1	8515	24.800	25.900	5.200	7.320	70.1	118	149	210	232	248	272	316	339
	20:1	8520	24.800	25.900	5.200	7.320	53.7	90.5	114	161	178	191	210	244	262
	25:1	8525	24.900	26.100	5.100	7.320	43.3	73.1	92.4	131	144	155	170	197	212
	30:1	8530	24.800	25.900	5.200	7.320	36.3	61.3	77.5	110	121	130	143	166	179
	40:1	8540	25.000	26.300	5.000	7.320	27.3	46.2	58.4	82.5	91.3	98.2	108	125	135
	50:1	8550	24.900	26.100	5.100	7.320	21.9	37.1	46.9	66.3	73.4	78.9	86.4	100	108
	60:1	8560	24.800	25.900	5.200	7.320	18.3	30.9	39.2	55.4	61.3	65.9	72.2	83.9	90.4
Size 180	5:1	8805	28.250	29.375	7.750	10.400	236	356	440	577	624	669	733	799	886
	8:1	8808	30.300	31.600	5.700	8.437	193	310	385	535	577	615	681	770	824
	10:1	8810	30.300	31.600	5.700	8.437	161	261	326	455	493	524	581	661	705
	15:1	8815	30.200	31.400	5.800	8.437	114	187	234	328	358	379	419	482	511
	20:1	8820	30.200	31.400	5.800	8.437	87.3	144	180	253	277	292	324	374	395
	25:1	8825	30.300	31.600	5.700	8.437	70.5	116	145	205	224	237	262	303	320
	30:1	8830	30.200	31.400	5.800	8.437	59.1	97.6	122	172	188	199	220	255	269
	40:1	8840	30.400	31.800	5.600	8.437	44.5	73.5	92.0	129	142	150	166	192	203
	50:1	8850	30.300	31.600	5.700	8.437	35.7	59.1	73.9	104	114	121	133	154	163
	60:1	8860	30.200	31.400	5.800	8.437	29.8	49.3	61.7	86.8	95.1	101	111	129	136

All ratings to the right of heavy line require force feed lubrication.

Special Gear Sets

The special center-distance size and ratio gear sets listed herein supplement our standard gear set line which is cataloged in previous pages.

Whenever possible, a standard gear set should be considered because these gear sets are made in quantity runs and are in stock. If it is not possible to use a standard gear set, a gear set from this listing may be applicable. Price and delivery will exceed standard gear set price and delivery, and will depend on which of the two following categories the gear set falls in. Please contact our Sales Office for specific information.

The special gear sets listed in the tool charts on the following pages are divided into two categories:

- I. Gear sets identified with an ** can be machined from standard blanks but are not to standard dimensions.
- II. The balance of the gear sets are made from special blanks.

In instances where gear sets are not designed to Cone Drive standard proportions due to limitations on worm or gear configuration, the ratings have been revised accordingly. We recommend reviewing the specific application in these instances with an Application Engineer before proceeding with the design.

Cone Drive gear sets are supplied in individually matched sets. Each set is inspected for tooth contact and smooth operation

with the gears on exact center-distance, and with correct end position of worm and side position of gear. After inspection an identifying set number is stamped on mating worm and gear. They should always be installed in matched sets, as marked. Tooling for hundreds of gear set combinations is available: from 3:1 to 240:1, with center-distances from .606" through 52.0".

Where a Cone Drive designed speed reducer cannot be used because of product design, space limitations, etc., and the gear set must be mounted in a specially designed housing, every effort should be made to follow the general design practice for Cone Drive gearing described in the General Information. If possible, standard mountings such as those illustrated in the General Information should be used.

Selection of the proper gear set depends upon the service characteristics under which the gears are to operate. Refer to page 9 for service factor information.

Cone Drive Gear Set Mountings

Mountings for gear sets with center distances from 1.5" through 28" are detailed in this section.

The mounting assemblies shown in this section are dimensionally identical to the mountings used in standard Cone Drive Speed Reducers.

Worm mountings are for either single or double-extended shafts horizontally mounted. Vertical worm mountings are available but requirement should be reviewed by Cone Drive application engineers to insure proper lubrication for upper bearing.

Gearshaft mountings are for either single extended, double extended, steeple bearings, or hollow gearshafts. The second suffix letter of these mountings indicates that gearshaft is vertically mounted.

U = shaft extended up

D = shaft extended down

V = shaft double extended up and down

When the second suffix letter is an 'O' it indicates the worm to be mounted over the gear.

CENTER DISTANCE (C.D.) TOLERANCE

SIZE	C.D.	TOLER.
15 to 120	1.500 to 12.000	±.001
150 to 280	15.000 to 28.000	±.003

Listed tolerances are Cone Drive housing bore dimensions. Manufactured gear set center distance is exact.

Cone Drive will furnish all parts shown for the mounting assembly selected except for the Cone worm, gear and gearshaft. These items must be ordered separately.

For worm and gear dimensions refer to this section.

For gearshaft dimensions refer to this section.

We furnish oilseals as shown for each type and if you require an alternate, please specify type required on your purchase order.

Cone Drive can supply either the complete mounting assembly or individual parts to meet your requirements.

Cone Drive Standard Worm Mountings and Bearings

Size 15 to 35

Standard "A" Mounting (Single Extended)
 Standard "E" Mounting (Double Extended)
 For Model HO, HU & HV

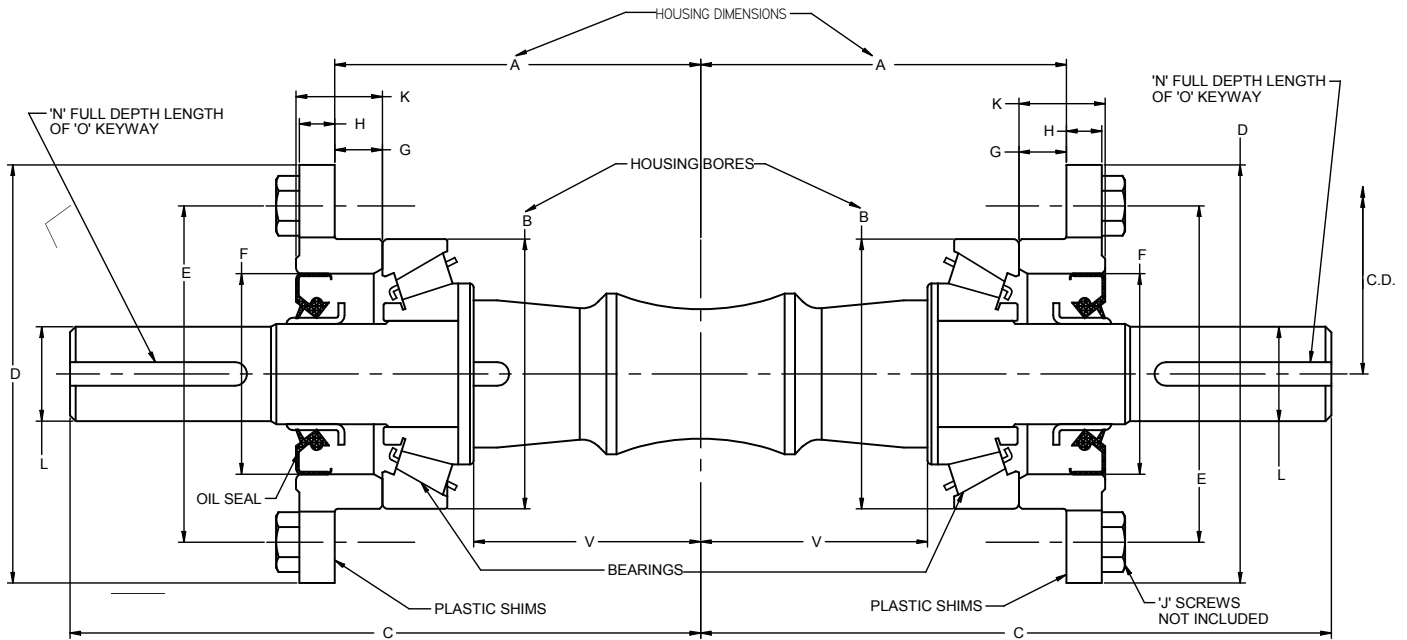

***Note:** SIZE 15 ONLY. THE WORM AND GEAR BEARING MOUNTINGS ARE IDENTICAL.
 CARRIER DIMENSIONS NOT SHOWN FOLLOW IN THIS SECTION.

Size	C.D.	A	B	C	D	E	F	G	H	J
*15	1.500	1.650	2.601 ± .001	3.000	"3.10 square"	3.15	1.250	—	0.156	4-1/4 -20
20	2.000	2.4375	2.125 + .001	4.59	3.25	2.69	1.500	0.160	0.28	4-5/16-24
25	2.500	3.125	2.563 + .001	5.25	3.75	3.12	1.6875	0.161	0.33	4-5/16- 24
30	3.000	3.875	2.860 + .001	6.69	4.43	3.56	2.125	0.504	0.38	6-3/8- 24
35	3.500	4.500	3.125 + .002	7.75	4.87	4	2.250	0.754	0.38	6-3/8-24

Size	K	L	N	O	V	TAPERED ROLLER BEARING		OIL SEAL LIP TYPE
						CONE DRIVE PART NUMBER	MANUFACTURER NUMBER	
15	—	0.625	0.75	3/16 x 3/32	1.000	LM11949 LM11910	LM11949-CONE LM11910-CUP	075A125
20	0.700	0.6875	1.06	3/16 x 3/32	1.406	321075 321212	21075-CONE 21212-CUP	075W150
25	0.742	0.750	1.00	3/16 x 3/32	2.093	323092 323256	23092-CONE 23256-CUP	087W168
30	0.915	1.000	1.75	1/4 x 1/8	2.406	341126 341286	41126-CONE 41286-CUP	106W212
35	0.815	1.1875	2.62	1/4 x 1/8	2.750	343132 343312	43132-CONE 43312-CUP	125W225

STANDARD WORM MOUNTING COMPLETE MOUNTING PARTS - LESS WORM		SIZE 15	SIZE 20	SIZE 25	SIZE 30	SIZE 35
MOUNTING DESCRIPTION	SINGLE EXTENDED STANDARD WITH LIP TYPE OIL SEAL	15A	20A	25A	30A	35A
	DOUBLE EXTENDED STANDARD WITH LIP TYPE OIL SEAL BOTH ENDS	15E	20E	25E	30E	35E

Cone Drive part numbers are shown in bold print.
 Mountings shown are for horizontally mounted worm.

For vertical type mounting contact Cone Drive.
 Additional parts are required to insure lubrication of upper bearings.

Cone Drive Standard Worm Mountings and Bearings

Size 40 to 80

Standard "FA" Mounting (Single Extended)
 Standard "FE" Mounting (Double Extended)
 For Model HO, HU & HV

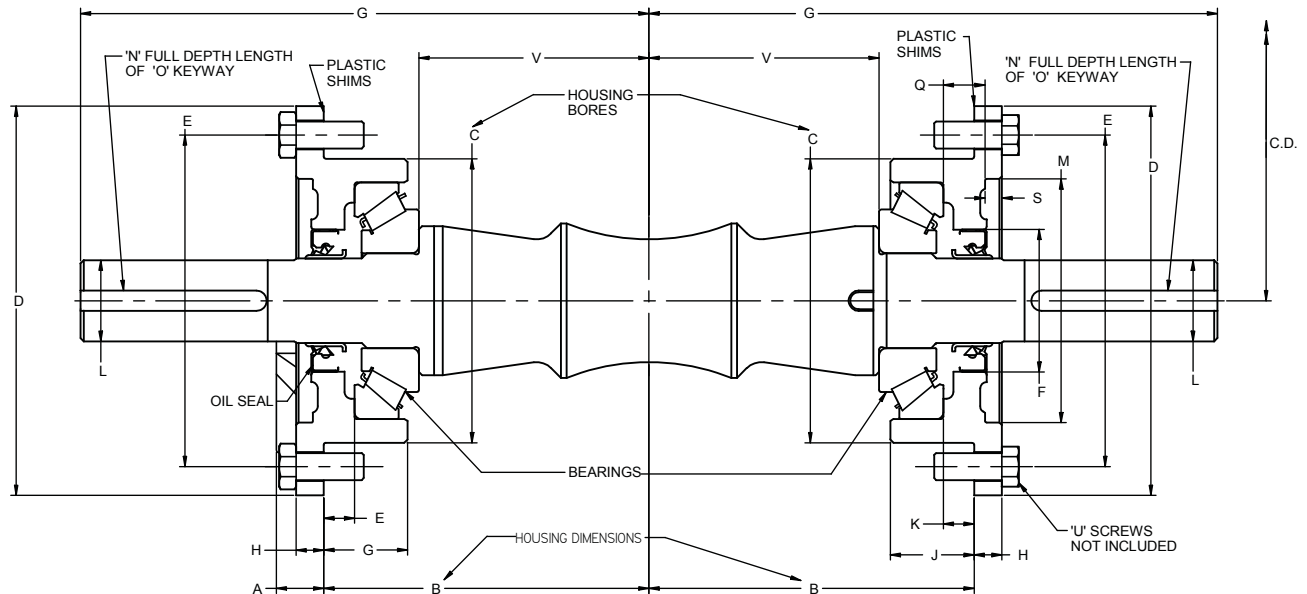

Note: ALL BOLT HOLES ARE SHOWN 30° OUT OF POSITION.

Size	C.D.	A	B	C	D	E	F	G	H	J	K	L
40F	4.000	0.88	5.187	4.625	6.38	5.375	2.625	9.31	0.437	1.56	.757±.002	1.500
50F	5.000	0.94	6.000	5.250	7.25	6.125	2.625	10.50	0.500	1.56	.570±.002	1.500
60F	6.000	1.00	6.625	6.125	8.12	7.000	2.875	11.75	0.560	1.72	.695±.002	1.750
70F	7.000	—	8.250	6.750	9.25	7.875	3.500	14.50	0.700	3.20	2.155±.005	1.875
80F	8.000	—	9.625	7.000	9.62	8.25	3.500	15.50	0.700	3.85	2.592±.005	2.000

Size	M	N	O	Q	S	U	V	TAPERED ROLLER BEARING		OIL SEAL LIP TYPE
								CONE DRIVE PART NUMBER	MANUFACTURER NUMBER	
40F	3.875	3.00	3/8 x 3/16	0.906	0.31	6-3/8-24	3.250	HM803146 HM803110	HM803146-CONE HM803110-CUP	156W262
50F	4.500	3.25	3/8 X 3/16	0.800	0.31	6-1/2-20	4.250	355175C 355437	55175C-CONE 55437-CUP	156W262
60F	5.000	4.00	3/8 X 3/16	0.962	0.43	6-1/2-20	4.500	372188C 372487	72188C-CONE 72487-CUP	181W287
70F	5.750	4.50	1/2 X 1/4	1.250	0.43	6-5/8-11	4.500	H913849 H913810	H913849-CONE H913810-CUP	212W350
80F	5.750	4.75	1/2 X 1/4	0.895	0.43	6-5/8-11	5.125	309285 309220	9285-CONE 9220-CUP	212W250

STANDARD WORM MOUNTING COMPLETE MOUNTING PARTS - LESS WORM		SIZE 40F	SIZE 50F	SIZE 60F	SIZE 70F	SIZE 80F
MOUNTING DESCRIPTION	SINGLE EXTENDED STANDARD WITH LIP TYPE OIL SEAL	40FA	50FA	60FA	70FA	80FA
	DOUBLE EXTENDED STANDARD WITH LIP TYPE OIL SEAL BOTH ENDS	40FE	50FE	60FE	70FE	80FE

Cone Drive part numbers are shown in bold print.
 Mountings shown are for horizontally mounted worm.

For vertical type mounting contact Cone Drive.
 Additional parts are required to insure lubrication of upper bearings.

Cone Drive Standard Worm Mountings and Bearings

Size 100 to 120

Standard "A" Mounting (Single Extended)
Standard "E" Mounting (Double Extended)
For Model HO, HU & HV

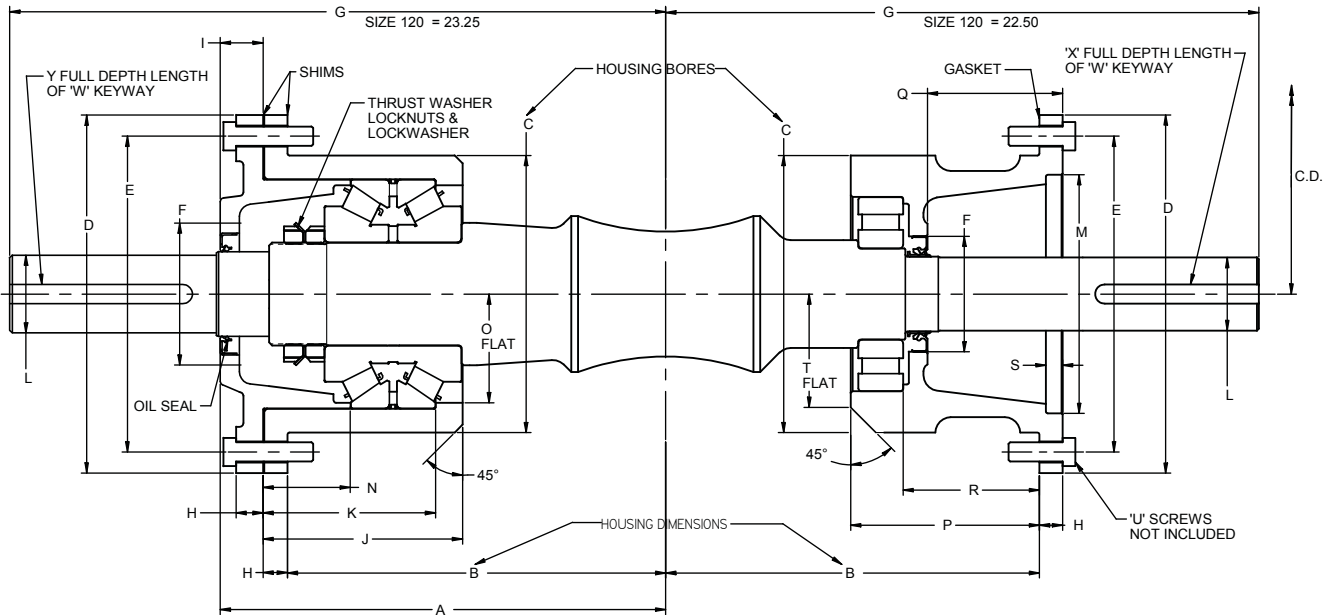

ALL BOLT HOLES ARE SHOWN 30° OUT OF POSITION.

TAPER ROLLER BEARINGS HAVE PREGROUND SPACERS TO CONTROL ENDPLAY OF BEARING.

SIZE	C.D.	A	B	C	D	E	F	G	H	I	J	K	L	M	N	O	P	Q	R	S	T	U
100	10.000	14.44	12.250	9.000	11.62	10.25	3.750	19.25	0.750	0.7	6.44	5.555	2.375	7.750	2.843	3.6	6.125	4.386	4.50	0.54	3.1	6-5/8-11
120	12.000	17.19	14.500	11.875	14.87	13.25	4.750	SEE ABOVE	0.750	1.83	7.62	6.656	3.000	10.250	2.328	4.1	8.06	5.166	5.25	0.75	3.6	6-3/4-10

SIZE	W	X	Y	BEARING ACCESSORIES			TAPERED ROLLER THRUST BEARING			CYLINDRICAL ROLLER RADIAL BEARING	OIL SEAL LIP
				THRUST WASHER	LOCK NUT (2)	LOCK WASHER	ASSEMBLY CONE DRIVE NUMBER	CONSISTING OF			
								CONE AND CONE SPACER	CUP AND CUP SPACER		
100	5/8 x 5/16	5.00	4.25	NOT REQ'D	155017 AN-17	155217 W-17	335311	90334 (2) X-1-S 90334	90744 (2) Y-4-S90744	240315 U-1315-L	243W375
120	3/4 x 3/8	5.87	4.50	155320 K91520	155020 AN-20	155220 W-20	334879	HH923649 (2) K84216	HH923610 (2) K84217	245217 U-5217-L	312W475

STANDARD WORM MOUNTING COMPLETE MOUNTING PARTS - LESS WORM		SIZE 100	SIZE 120
MOUNTING DESCRIPTION	SINGLE EXTENDED STANDARD WITH LIP TYPE OIL SEAL	100A	120A
	DOUBLE EXTENDED STANDARD WITH LIP TYPE OIL SEAL BOTH ENDS	100E	120E

Cone Drive part numbers are shown in bold print. Mountings shown are for horizontally mounted worm.

For vertical type mounting contact Cone Drive. Additional parts are required to insure lubrication of upper bearings.

Cone Drive Standard Worm Mountings and Bearings

Size 150 to 180

Standard "A" Mounting (Single Extended)
 Standard "E" Mounting (Double Extended)
 For Model HO, HU & HV

Alternate "B" Mounting (Single Extended)
 Alternate "H" Mounting (Double Extended)
 Available on Special Order Only

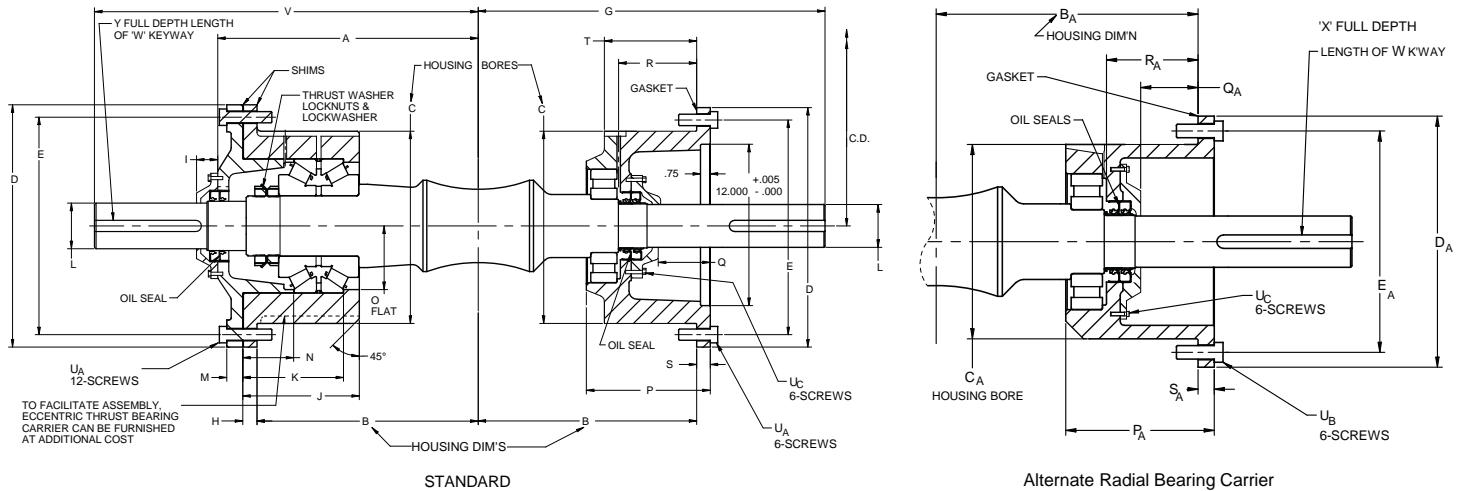

NOTE: TAPERED ROLLER BEARINGS HAVE PRE-GROUND SPACERS TO CONTROL ENDPLAY OF BEARING.

SIZE	C.D.	A	B	C	D	E	G	H	I	J	K	L	M	N	O	P
150	15.000	20.50	16.750	13.500	17.00	15.25	26.25	0.937	1.00	8.12	6.850	3.500	1.00	1.900	5.3	7.75
180	18.000	21.68	18.500	14.500	18.38	16.38	30.12	1.000	1.06	9.25	7.913	4.000	1.00	2.963	5.1	9.25

SIZE	Q	R	S	T	V	W	X	Y	B _A	C _A	D _A	E _A	P _A	R _A	S _A	Q _A
150	3.37	4.87	0.750	5.5	27.87	7/8 x 7/16	8.50	5.50	15.750	7.750	9.75	8.75	6.50	3.87	0.500	2.12
180	4.06	5.47	1.000	6.4	31.50	1 x 1/2	10.00	7.50	17.125	9.000	11.50	10.25	7.38	4.09	0.500	2.18

The bearings shown are for illustration, Cone Drive will select bearings which are best suited for the application and meet the needs for performance and delivery.

STANDARD WORM MOUNTING COMPLETE MOUNTING PARTS - LESS WORM		SIZE 150	SIZE 180
MOUNTING DESCRIPTION	SINGLE EXTENDED STANDARD WITH LIP TYPE SEAL	150A	180A
	SINGLE EXTENDED ALTERNATE WITH LIP TYPE SEAL	150B	180B
	DOUBLE EXTENDED STANDARD WITH LIP TYPE SEAL BOTH ENDS	150E	180E
	DOUBLE EXTENDED ALTERNATE WITH LIP TYPE SEAL BOTH ENDS	150H	180H

Cone Drive part numbers are shown in bold print.
 Mountings shown are for horizontally mounted worm.
 For vertical type mounting contact Cone Drive.
 Additional parts are required to insure lubrication of upper bearings.

** Assemble 2 inner seals with lip inward and outer seal with lip outward.

Cone Drive Standard Worm Mountings and Bearings

Size 220 to 280

Standard "A" Mounting (Single Extended)
 Standard "E" Mounting (Double Extended)
 For Model HO, HU & HV

Alternate "B" Mounting (Single Extended)
 Alternate "H" Mounting (Double Extended)
 Available on Special Order Only

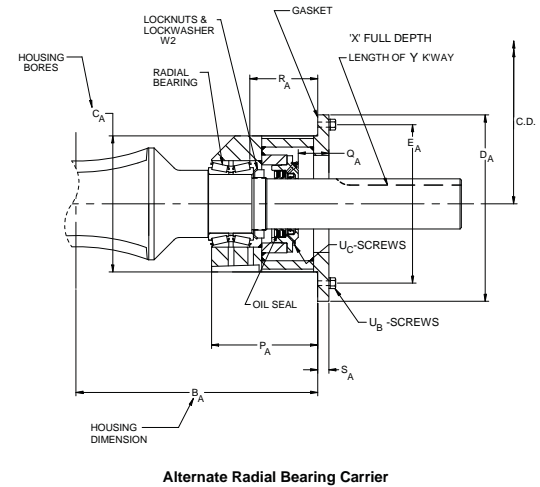
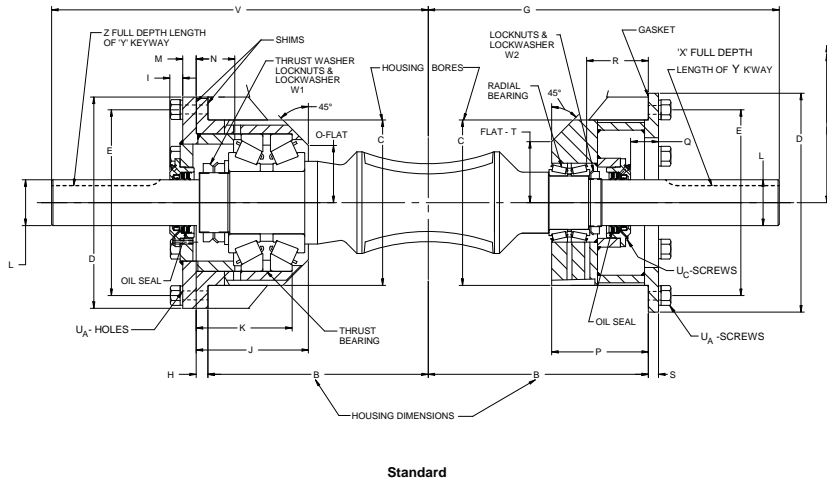

NOTE: TAPERED ROLLER BEARINGS HAVE PRE-GROUND SPACERS TO CONTROL ENDPLAY OF BEARING.

SIZE	C.D.	B	C	D	E	G	H	I	J	K	L	M	N	O	P	Q
220	21.837	21.625	16.250	20.75	18.25	34.50	1.125	1.4	11.00	9.400	4.500	1.22	4.448	5.6	10.50	2.50
240	24.000	24.500	17.500	22.50	19.75	40.00	1.250	0.3	12.50	10.965	5.000	1.25	5.885	6.6	12.50	3.12
280	28.000	29.750	22.503	28.00	25.25	46.00	1.500	2.0	14.18	12.173	6.000	1.55	5.453	9.0	14.88	4.18

SIZE	R	S	T	U _{ARC}	V	X	Y	Z	B _A	C _A	D _A	E _A	P _A	Q _A	R _A	S _A
220	5.94	1.00	5.7	A-12-1 1/8-7 B-6-3/4-10 C-6-3/8-16	37.00	10.00	1 X 1/2	9.50	19.500	10.875	13.87	12.25	8.38	.37	3.81	1.00
240	7.06	1.00	6.5	A-12-1 1/4 -8 B- 8- 5/8-11 C- 6- 3/8-16	40.00	10.00	1 1/4 X 7/16	9.75	24.500	13.500	16.50	15.00	12.25	2.87	7.06	.75
280	8.50	1.50	8.5	A-12-1 1/2-6 C-6-3/4-10	46.00	13.00	1 1/2 X 1/2	9.00								

“The bearings shown are for illustration, Cone Drive will select bearings which are best suited for the application and meet the needs for performance and delivery.”

STANDARD WORM MOUNTING COMPLETE MOUNTING PARTS - LESS WORM		SIZE 220	SIZE 240	SIZE 280
MOUNTING DESCRIPTION	SINGLE EXTENDED STANDARD WITH LIP TYPE SEAL	220A	240A	280A
	SINGLE EXTENDED ALTERNATE WITH LIP TYPE SEAL	220B	240B	
	DOUBLE EXTENDED STANDARD WITH LIP TYPE SEAL BOTH ENDS	220E	240E	280E
	DOUBLE EXTENDED ALTERNATE WITH LIP TYPE SEAL BOTH ENDS	220H	240H	

Cone Drive part numbers are shown in bold print.
 Mountings shown are for horizontally mounted worm.
 For vertical type mounting contact Cone Drive.

Additional parts are required to insure lubrication of upper bearings.
 ** Assemble 2 inner seals with lip inward and outer seal with lip outward.

Cone Drive Standard Gearshaft Mountings and Bearings

Size 15 to 35

Single and Double Extended

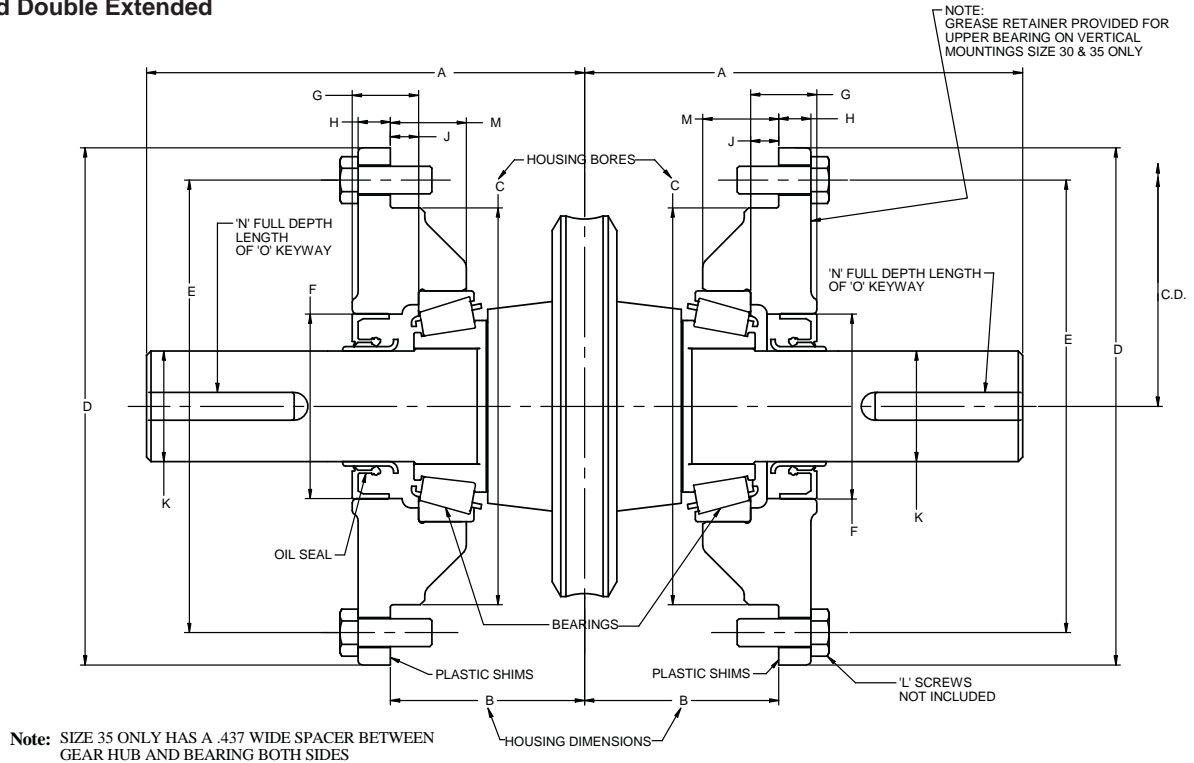

Size	C.D.	A	B	C	D	E	F	G	H	J
15	1.500	3.10	1.650	2.600+ .002	3.10	3.15	1.250	0.366	0.156	0.166
20	2.000	4.06	1.625	3.5005 + .0015	4.75	4.12	2.125	0.733	0.312	0.007
25	2.500	4.50	2.000	4.3755 + .0015	5.69	4.94	2.250	0.860	0.375	0.257
30	3.000	5.94	2.625	5.375 + .002	7.00	6.12	2.500	0.898	0.437	0.382
35	3.500	7.87	3.500	6.500 + .002	8.12	7.25	3.250	0.960	0.437	0.414

Size	K	L	M	N	O	TAPERED ROLLER THRUST BEARING		OIL SEAL LIP
						CONE DRIVE PART NUMBER	MANUFACTURERS PART NUMBER	
15	0.75	4-1/4-20	0.50	0.80	3/16 x 3/32	LM11949 LM11910-CUP	LM11949-CONE LM11910-CUP	075A125
20	1.125	4-5/16-24	0.65	1.19	1/4 x 1/8	15117-CONE 15245-CUP	15117-CONE 15245-CUP	112W212
25	1.250	8-5/16-24	0.94	1.38	1/4 x 1/8	02875-CONE 02820-CUP	02875-CONE 02820-CUP	125W225
30	1.500	6-3/8-24	1.03	2.00	3/8 x 3/16	26881-CONE 26822-CUP	26881-CONE 26822-CUP	150W250
35	1.875	6-3/8-24	1.44	2.68	1/2 x 1/4	33890-CONE 33821-CUP	33890-CONE 33821-CUP	200W325

STANDARD GEARSHAFT MOUNTING COMPLETE MOUNTING PARTS - LESS GEAR & SHAFT		SIZE 15	SIZE 20	SIZE 25	SIZE 30	SIZE 35
MOUNTING DESCRIPTION	SINGLE EXTENDED - HORIZONTAL	15J	20J	25J	30J	35J
	SINGLE EXTENDED - SHAFT VERTICAL UP			25JU	30JU	35JU
	SINGLE EXTENDED - SHAFT VERTICAL DOWN			25JD	30JD	35JD
	DOUBLE EXTENDED - HORIZONTAL	15K	20K	25K	30K	35K
	DOUBLE EXTENDED - SHAFT VERTICAL			25KV	30KV	35KV

Cone Drive part numbers are shown in bold print.

Cone Drive Standard Gearshaft Mountings and Bearings

Size 40 to 70

Single and Double Extended

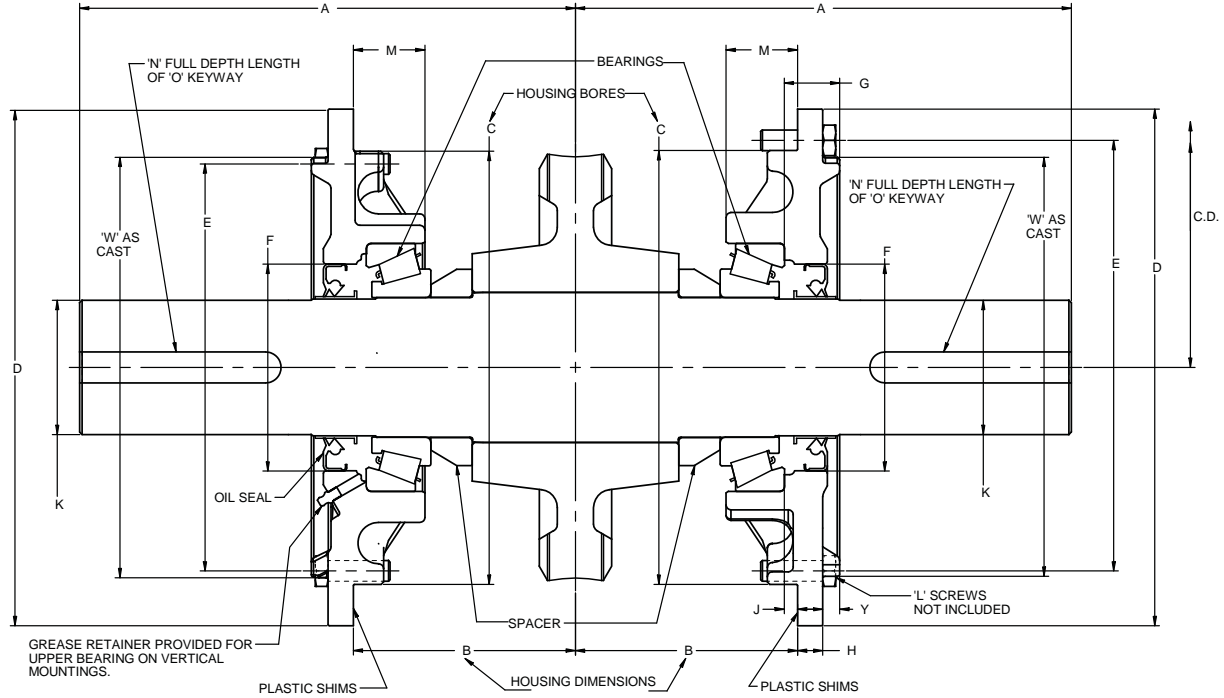

Size	C.D.	A	B	C	D	E	F	G	H	J	K
40	4.000	9.25	4.125	7.250	9.00	8.00	3.750	1.050	0.437	.385 ± .002	2.25
50	5.000	10.31	4.750	9.000	11.00	9.87	4.500	1.102	0.500	.573 ± .002	2.75
60	6.000	12.00	5.375	10.500	12.50	11.38	5.000	1.045	0.593	.322 ± .002	3.25
70	7.000	13.00	6.250	12.500	15.00	13.75	5.250	1.140	0.687	.806 ± .005	3.375

Size	L	M	N	O	W	Y	TAPERED ROLLER THRUST BEARING		OIL SEAL LIP TYPE
							CONE DRIVE PART NUMBER	MANUFACTURERS PART NUMBER	
40	6 - 3/8 - 24	1.56	3.31	1/2 x 1/4	7.12	0.19	303977 303920	3977-CONE 3920-CUP	231W375
50	6 - 1/2 - 20	1.87	3.62	5/8 x 5/16	9.00	0.19	300567 300563	567-CONE 563-CUP	281W450
60	6 - 1/2 - 20	1.75	4.5	3/4 x 3/8	10.25	0.41	300596 300592A	596-CONE 592A-CUP	331W500
70	6 - 5/8 - 11	2.43	4.87	7/8 x 7/16	12.25	0.32	300760 300752	760-CONE 752-CUP	350W525

STANDARD GEARSHAFT MOUNTING COMPLETE MOUNTING PARTS - LESS GEAR & SHAFT		SIZE 40	SIZE 50	SIZE 60	SIZE 70
MOUNTING DESCRIPTION	SINGLE EXTENDED - HORIZONTAL	40L	50L	60L	70L
	SINGLE EXTENDED - SHAFT VERTICAL UP	40LU	50LU	60LU	70LU
	SINGLE EXTENDED - SHAFT VERTICAL DOWN	40LD	50LD	60LD	70LD
	DOUBLE EXTENDED - HORIZONTAL	40M	50M	60M	70M
	DOUBLE EXTENDED - SHAFT VERTICAL	40MV	50MV	60MV	70MV

Cone Drive part numbers are shown in bold print.

Cone Drive Standard Gearshaft Mountings and Bearings

Size 80 to 120

Single and Double Extended

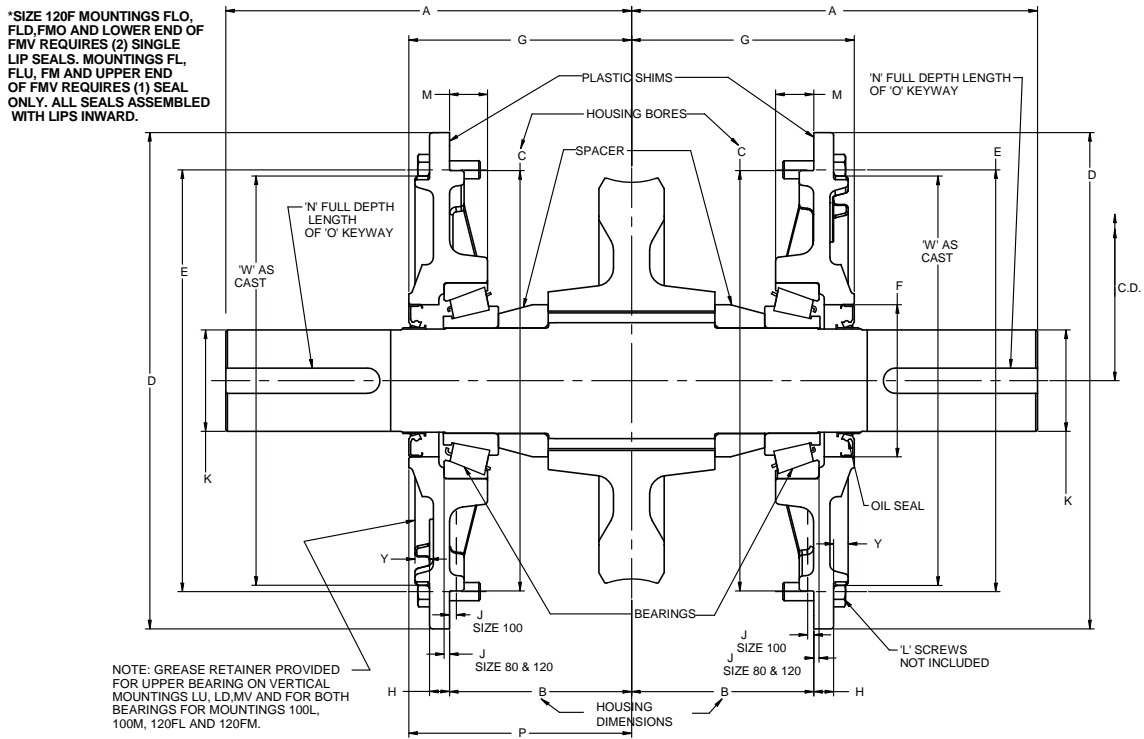

Size	A	B	C	D	E	F	G	H	J	K	L Holes	M
80	14.00	6.250	14.500	17.12	15.75	5.250	7.68	0.687	0.186	3.500	8 5/8-11	1.31
100	15.72	8.000	17.750	20.50	19.12	6.000	9.00	0.812	0.652	4.000	12-5/8-11	2.03
120F	24.00	10.375	21.500	24.50	23.00	7.500	12.36	0.875	0.450	5.497	12-3/4-10	1.93

Size	N	O	P	W	Y	TAPERED ROLLER THRUST BEARING		OIL SEAL LIP TYPE
						CONE DRIVE PART NUMBER	MANUFACTURERS PART NUMBER	
80	4.87	7/8 x 7/16	7.84	14.25	0.5	377362 377675	77362-CONE 77675-CUP	356W525
100	5.12	1 x 1/2	9.25	16.82	0.38	371412 371750	71412-CONE 71750-CUP	406W600
120F	7.62	1 1/4 x 5/8	12.5	20.5	—	EE107057 107105	EE107057-CONE 107105-CUP	550A750

STANDARD GEARSHAFT MOUNTING COMPLETE MOUNTING PARTS - LESS GEAR & SHAFT		SIZE 80	SIZE 100	SIZE 120F
MOUNTING DESCRIPTION	SINGLE EXTENDED - HORIZONTAL - WORM MOUNTED UNDER GEAR	80L	100L	120FL
	SINGLE EXTENDED - HORIZONTAL - WORM MOUNTED OVER GEAR	80LO	100LO	120FLO
	SINGLE EXTENDED - SHAFT VERTICAL UP	80LU	100LU	120FLU
	SINGLE EXTENDED - SHAFT VERTICAL DOWN	80LD	100LD	120FLD
	DOUBLE EXTENDED - HORIZONTAL - WORM MOUNTED UNDER GEAR	80M	100M	120FM
	DOUBLE EXTENDED - HORIZONTAL - WORM MOUNTED OVER GEAR	80MO	100MO	120FMO
	DOUBLE EXTENDED - SHAFT VERTICAL	80MV	100MV	120FMV

* See note above for size 120F.
 Cone Drive part numbers are shown in bold print.

Cone Drive Standard Gearshaft Mountings and Bearings

Size 150 to 280

Horizontal Mounting Single and Double Extended

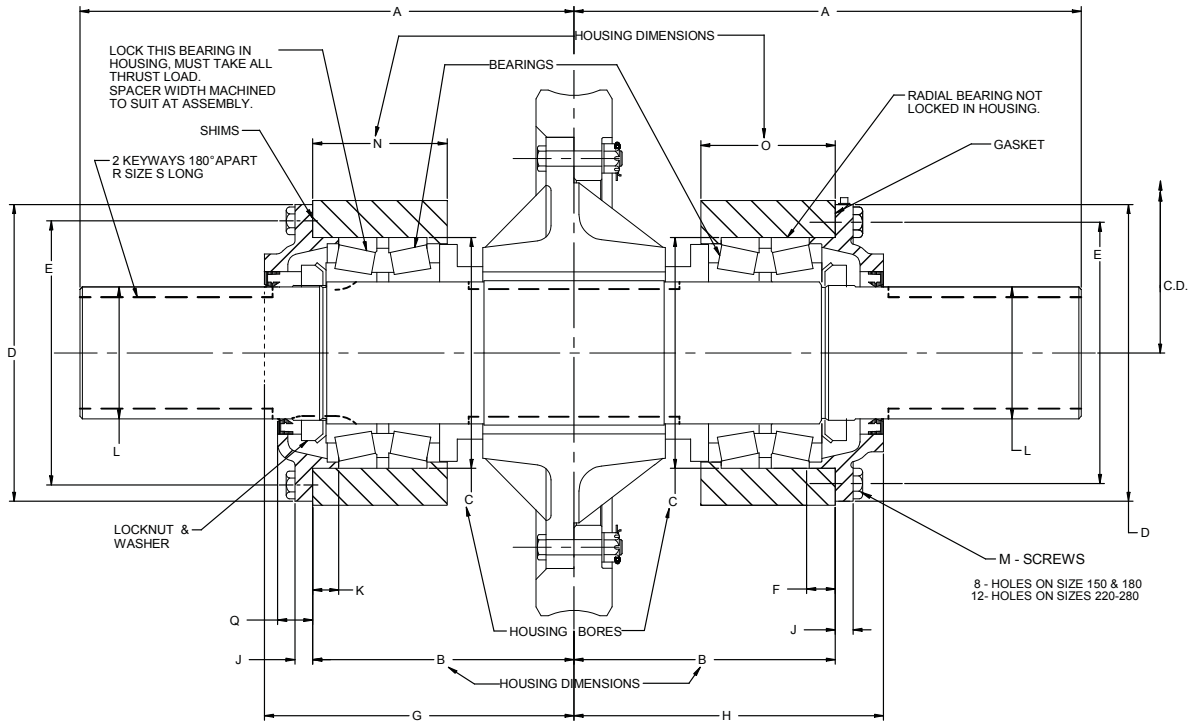

LOCATE LARGE END OF SPACERS TOWARD BEARINGS ON MOUNTING.

ALL OIL SEAL LIPS TO FACE INWARD.

Size	C.D.	A	B	C	D	E	F	G	H	J	K	L	M	N
150	15.000	25.00	12.875	11.377 + .002	14.62	12.87	1.000	15.50	15.50	.875	1.281	6.500	3/4 - 10	5.625
180	18.000	28.75	15.125	12.503 + .003	15.75	14.00	1.250	17.75	17.75	.875	1.531	7.500	3/4 - 10	5.875
220	21.837	36.00	19.750	14.003 + .003	18.00	16.12	1.812	22.62	22.62	1.000	2.156	9.000	1" x 8	6.500
240	24.000	38.00	19.500	15.753 + .003	20.50	18.50	1.500	23.12	23.12	1.125	1.781	10.000	1" x 8	6.000
280	28.000	48.00	26.500	19.003 + .003	24.00	21.50	2.750	29.00	29.00	1.250	3.028	12.000	1 1/4 x 7	8.000

The bearings shown are for illustration, Cone Drive will select bearings which are best suited for the application and meet the needs for performance and delivery.

STANDARD GEARSHAFT MOUNTING COMPLETE MOUNTING PARTS - LESS GEAR & SHAFT		SIZE 150	SIZE 180	SIZE 220	SIZE 240	SIZE 280
MOUNTING DESCRIPTION	SINGLE EXTENDED - HORIZONTAL - WORM MOUNTED UNDER GEAR	150L	180L	220L	240L	280L
	SINGLE EXTENDED - HORIZONTAL - WORM MOUNTED OVER GEAR	150JO	180JO	220JO	240JO	280JO
	DOUBLE EXTENDED - HORIZONTAL - WORM MOUNTED UNDER GEAR	150K	180K	220K	240K	280K
	DOUBLE EXTENDED - HORIZONTAL - WORM MOUNTED OVER GEAR	150KO	180KO	220KO	240KO	280KO

For Vertical Mounting see following page.

Cone Drive part numbers are shown in bold print.

Cone Drive Standard Gearshaft Mountings - Vertical Size 150 to 280

UPPER BEARING IS LOCKED IN CARRIER MUST TAKE ALL THRUST LOAD,
 SPACER WIDTH MACHINED TO SUIT AT ASSEMBLY.

UPPER BEARING TO BE GREASE PACKED FOR LUBRICATION

SIZE	CARRIER BOLT HOLES			
	TOP		BOTTOM	
	NUMBER	DIA.	NUMBER	DIA.
150	12	5/8-11	8	3/4 - 10
180	12	5/8-11	8	3/4 - 10
220	12	1" - 8	8	1" - 8
240	12	1" - 8	8	1" - 8
280	16	1 1/4 X 7	12	1 1/4 - 7

SIZE	EXTENSION KEYWAYS	
	SIZE	LENGTH
150	(2) 1 1/2 x 1/2	9.50
180	(2) 1 3/4 x 5/8	8.00
220	(2) 2 1/2 x 7/8	8.00
240	(2) 2 1/2 x 7/8	8.00
280	(2) 3 x 1	12.00

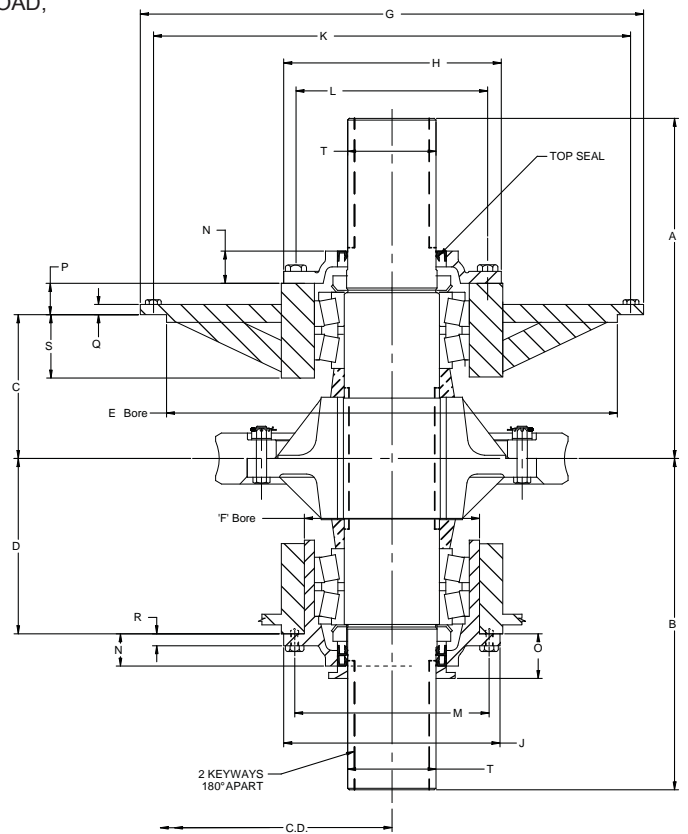

SIZE	C.D.	A	B	C	D	E	F	G	H	J	K	L	M
150	15.000	25.00	30.00	11.500	14.000	27.000	13.500	29.9	14.7	17.0	28.37	12.87	15.25
180	18.000	28.75	34.75	12.750	16.500	32.750	14.500	35.8	15.8	18.5	34.12	14.00	16.37
220	21.837	36.00	42.50	16.000	21.625	39.500	16.750	44.0	18.0	21.2	41.50	16.12	19.00
240	24.000	38.00	46.00	17.000	22.125	44.000	18.750	49.5	20.5	23.3	46.75	18.50	21.00
280	28.000	48.00	55.00	21.500	26.250	50.500	22.500	56.0	23.0	27.8	53.00	21.50	24.75

The bearings shown are for illustration, Cone Drive will select bearings which are best suited for the application and meet the needs for performance and delivery.

STANDARD GEARSHAFT MOUNTING COMPLETE MOUNTING PARTS - LESS GEAR & SHAFT		SIZE 150	SIZE 180	SIZE 220	SIZE 240	SIZE 280
MOUNTING DESCRIPTION	SINGLE EXTENDED - SHAFT VERTICAL UP	150NU	180NU	220NU	240NU	280NU
	SINGLE EXTENDED - SHAFT VERTICAL DOWN	150ND	180ND	220ND	240ND	280ND
	DOUBLE EXTENDED - SHAFT VERTICAL	150PV	180PV	220PV	240PV	280PV

For Gearshaft dimensions not shown contact Cone Drive.

Cone Drive part numbers are shown in bold print.

Cone Drive Standard Gearshaft Mountings and Bearings

Size 20 to 35

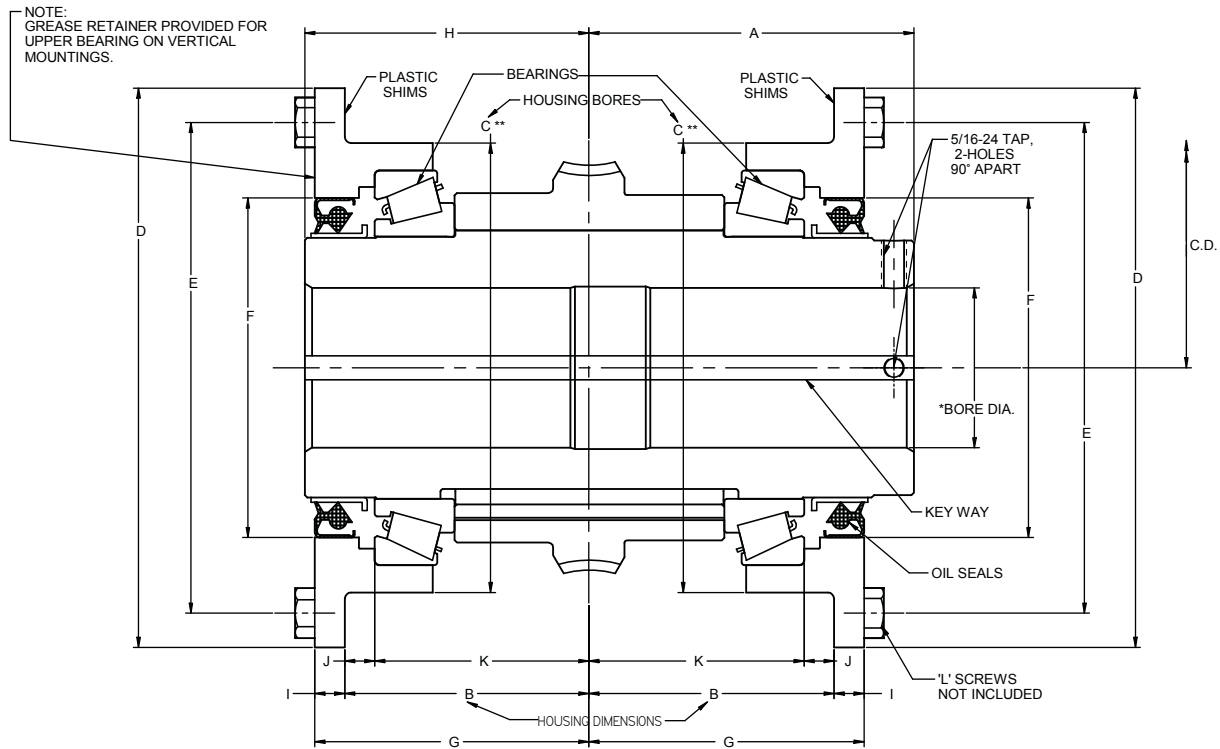

*SEE GEAR SHAFT CHART FOR BORE SIZES FOLLOWING IN THIS SECTION.
 **ON SIZES 20 & 25 THE BEARINGS SET DIRECTLY IN HOUSING BORE.

Size	C.D.	A	B	C	D	E	F	G	H
20	2.000	3.06	1.625	± .0015 3.5005	4.75	4.12	2.687	2.43	2.62
25	2.500	3.12	2.000	± .0015 4.3755	5.69	4.94	3.500	2.41	2.68
30	3.000	4.06	2.625	± .002 5.375	7.00	6.12	4.250	3.38	3.56
35	3.500	4.62	3.500	± .002 6.500	8.12	7.25	4.750	3.94	4.18

SIZE	I	J	K	L HOLES		TAPERED ROLLER BEARING		OIL SEAL LIP TYPE
				NO.	SIZE	CONE DRIVE PART NUMBER	MANUFACTURERS PART NUMBER	
20	.375	-.118	1.750	4	5/16 - 24	300368 300362A	368-CONE 362A-CUP	193W268
25	.375	.203	-	8	5/16 - 24	30399A 30393AS	399A-CONE 393AS-CUP	262W350
30	.437	-0.56	2.687	6	3/8 - 24	327689 327620	27689-CONE 27620-CUP	325W425
35	.437	.382	-	6	3/8 - 24	342368 342584	42368-CONE 42584-CUP	362W475

STANDARD GEARSHAFT MOUNTING COMPLETE MOUNTING PARTS - LESS GEAR & SHAFT		SIZE 20	SIZE 25	SIZE 30	SIZE 35
MOUNTING DESCRIPTION	SINGLE EXTENDED - SHAFT HORIZONTAL	S20 J	S25 J	S30 J	S35 J
	SINGLE EXTENDED - SHAFT VERTICAL UP	S20 JU	S25 JU	S30 JU	S35 JU
	SINGLE EXTENDED - SHAFT VERTICAL DOWN	S20 JD	S25 JD	S30 JD	S35 JD

Cone Drive part numbers are shown in bold print.

Cone Drive Standard Hollow Shaft Gear Mountings and Bearings Size 40 to 120

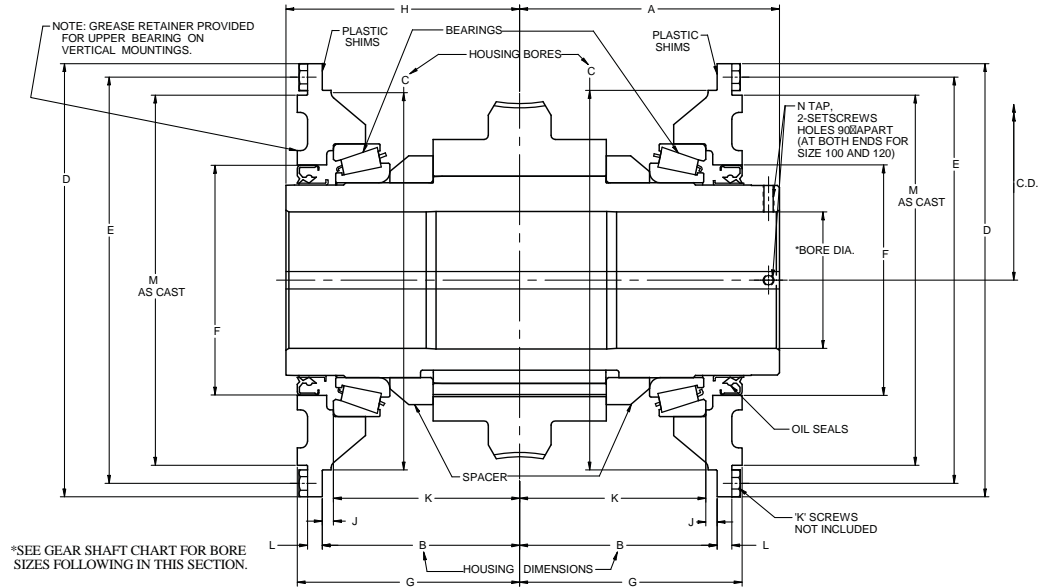

Size	C.D.	A	B	C	D	E	F	G	H	J
40	4.000	5.87	± .001 4.125	7.250	9.00	8.00	5.000	5.00	5.19	± .002 .322
50	5.000	6.25	± .001 4.750	9.000	11.00	9.87	6.250	5.47	5.75	± .002 .386
60	6.000	7.50	± .001 5.375	10.500	12.50	11.38	6.625	6.38	6.75	± .002 .260
70	7.000	8.75	± .001 6.250	12.500	15.00	13.75	8.375	7.43	7.75	± .005 .270
80	8.000	8.75	± .001 6.250	14.500	17.12	15.75	8.375	7.43	7.75	± .005 .270
100	10.000	10.62	± .002 8.000	17.750	20.50	19.12	10.000	9.38	10.62	± .005 .300
120	12.000	14.00	± .002 10.375	21.500	24.50	23.00	11.750	12.25	14.00	± .005 .780

Size	K HOLES		L	M	N	TAPERED ROLLER BEARING		OIL SEAL LIP TYPE
	NO.	SIZE				CONE DRIVE PART NUMBER	MANUFACTURER PART NUMBER	
40	6	3/8 - 24	.47	-	5/16 - 24	356418 356650	56418-CONE 56650-CUP	400W500
50	6	1/2 - 20	.50	-	5/16 - 24	348286 348220	48286-CONE 48220-CUP	475W625
60	6	1/2 - 20	.58	10.25	5/16 - 24	348685 348620	48685-CONE 48620-CUP	550W662
70	6	5/8 - 11	.68	12.38	1/2 - 20	300760 300752	67790-CONE 67720-CUP	687W837
80	8	5/8 - 11	.68	14.38	1/2 - 20	367790 367720	67790-CONE 67720-CUP	687W837
100	12	5/8 - 11	.82	16.82	1/2 - 20	367985 367920	67985-CONE 67920-CUP	800D1000
120	12	3/4 - 10	.80	-	1/2 - 20	LM451349 LM451310	LM451349-CONE LM451310-CUP	1000A1175(2)

STANDARD GEARSHAFT MOUNTING COMPLETE MOUNTING PARTS - LESS GEAR & SHAFT		SIZE 40	SIZE 50	SIZE 60	SIZE 70	SIZE 80	SIZE 100	SIZE 120
MOUNTING DESCRIPTION	SINGLE EXTENDED - SHAFT HORIZONTAL	S40 J	S50 J	S60 J	S70 J	S80 J		
	SINGLE EXTENDED - SHAFT VERTICAL UP	S40 JU	S50 JU	S60 JU	S70 JU	S80 JU		
	SINGLE EXTENDED - SHAFT VERTICAL DOWN	S40 JD	S50 JD	S60 JD	S70 JD	S80 JD		
	DOUBLE EXTENDED - SHAFT HORIZONTAL						S100 K	S120 K
	DOUBLE EXTENDED - SHAFT VERTICAL						S100 KV	S120

Cone Drive part numbers are shown in bold print.

Cone Drive Standard Solid Gearshafts

Size 15 to 280

* SIZE 25 DOUBLE EXTENDED D = 3.44 (CENTER KEYWAY LENGTH = 1.69)

M 2-KEYWAYS 180° APART

SECTION A-A
SIZE 40 -120

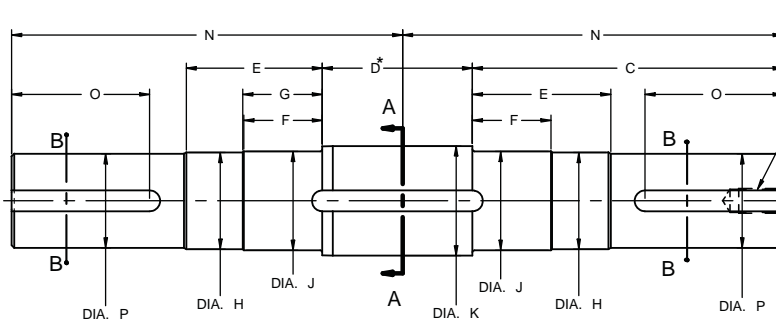

TAPPED HOLE BOTH ENDS
SIZE 50-120

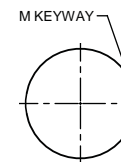

SECTION A-A
SIZE 20 - 35

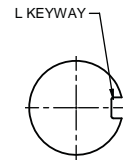

SECTION B-B

REFER TO SECTION G FOR GEARSHAFT MATERIAL

SIZE	C.D.	C	D	E	F	G	H ±.002	J -.001	K -.001	L	M	N	O	P -.001
15	1.500						.750	.750	.750	3/16 x 3/32	3/16 x 3/32	3.10	.80	.750
20	2.000	3.22	1.69		.843	.812		1.1825	1.2520	1/4 x 1/8	1/4 x 1/8	4.06	1.19	1.125
25	2.500	2.78	3.47						1.2520	1/4 x 1/8	1/4 x 1/8	4.50	1.38	1.250
30	3.000	4.66	2.56		1.00	1.03		1.5645	1.6270	3/8 x 3/16	3/8 x 3/16	5.93	2.00	1.500
35	3.500	6.38	3.00	2.81	1.50	1.53	2.000	2.0645	2.1900	1/2 x 1/4	1/2 x 1/4	7.87	2.68	1.875
40	4.000	7.45	3.60	3.26	1.88	1.91	2.3125	2.3642	2.6275	1/2 x 1/4	1/2 x 1/4	9.25	3.31	2.250
50	5.000	8.20	4.22	3.48	1.98	2.04	2.8125	2.8775	3.1275	5/8 x 5/16	5/8 x 5/16	10.31	3.62	2.750
60	6.000	9.51	4.97	3.86	2.32	2.38	3.3125	3.3775	3.6275	3/4 x 3/8	3/4 x 3/8	12.00	4.50	3.250
70	7.000	10.51	4.97	4.40	2.98	3.04	3.500	3.5650	4.0025	7/8 x 7/16	7/8 x 7/16	13.00	4.87	3.375
80	8.000	11.14	5.72	5.04	3.54	3.58	3.5625	3.6275	4.0025	7/8 x 7/16	7/8 x 7/16	14.00	4.87	3.500
100	10.000	12.78	5.87	6.34	4.38	4.41	4.0625	4.1275	4.253	1" x 1/2	1" x 3/8	15.72	5.12	4.000
120F	12.000	20.66	6.69	10.50	7.50	7.62	5.500	5.7540	6.128	1 1/4 x 5/8	1 1/4 x 7/16	24.00	7.62	5.497

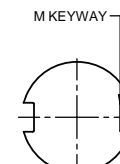
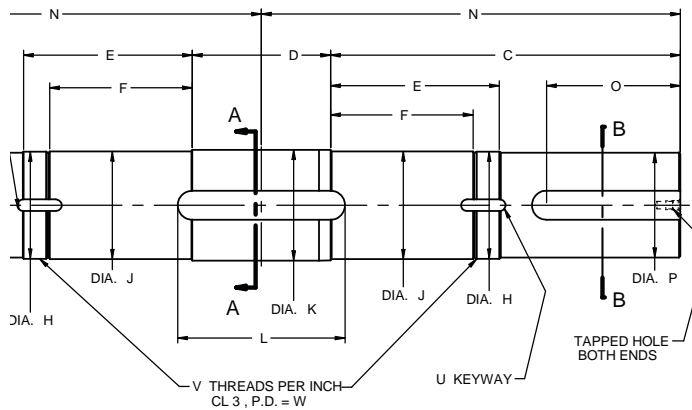

SECTION A-A

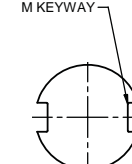

SECTION B-B

REFER TO SECTION G FOR GEARSHAFT MATERIAL

SIZE	C.D.	C	D	E	F	H ±.002	J -.001	K -.001	L	M	N	O	P -.001	U	V	W
150	15.000	20.56	8.88	9.44	7.75	6.659	7.0045	7.129	10.37	1 1/2 X 1/2	25.00	9.50	6.500	3/4 X 7/32	8	6.578
180	18.000	23.56	10.38	10.81	9.06	7.847	8.005	8.129	12.12	1 3/4 x 5/8	28.75	10.75	7.500	7/8 x 7/32	8	7.766
220	21.837	30.06	11.88	14.56	12.25	9.200	9.2555	9.504	14.37	2 1/2 x 7/8	36.00	12.75	9.000	1" x 7/32	8	9.119
240	24.000	31.06	13.88	14.06	11.56	10.200	10.256	10.504	16.37	2 1/2 x 7/8	38.00	14.00	10.000	1" x 7/32	8	10.119
280	28.000	39.56	16.88	18.56	15.94	12.875	13.0085	13.255	16.87	3 x 1"	48.00	17.00	12.000	1" x 1/4	8	12.794

Contact Cone Drive for additional gearshaft dimensions when required.

Cone Drive Standard Hollow Gearshafts

Size 20 to 80

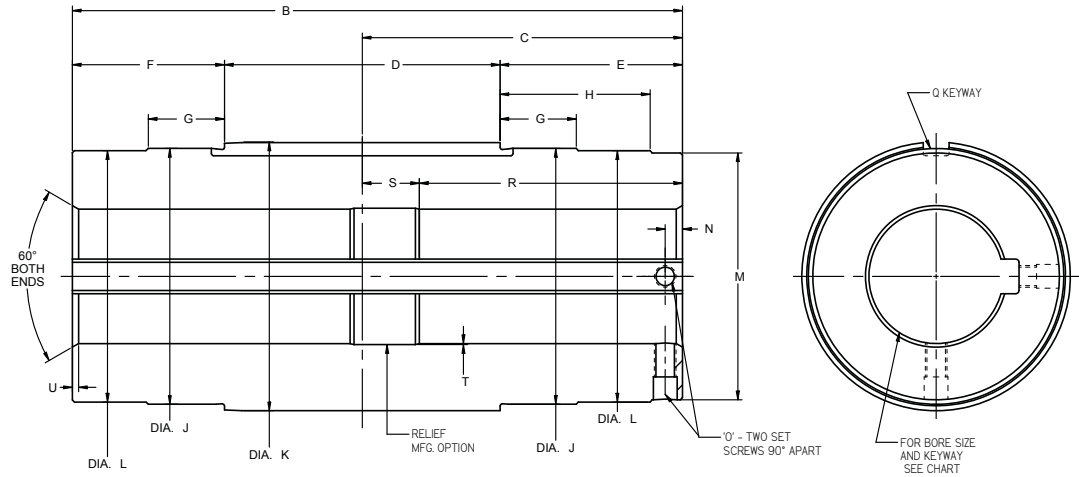

THIS SHAFT WILL USE A HOLLOW SHAFT GEAR, PRECEEDING IN THIS SECTION MATERIAL - CONE DRIVE OPTION - STEEL OR DUCTILE IRON.

BORE INCHES	GEARSHAFT NUMBER	KEYWAY SIZE	BORE INCHES	GEARSHAFT NUMBER	KEYWAY SIZE	BORE INCHES	GEARSHAFT NUMBER	KEYWAY SIZE
SIZE 20			SIZE 30			SIZE 40		
1.375*	20-S60-106	1/4 X 1/8	2.500	30-S60-208	3/8 X 3/16	2.9375*	40-S60-215	5/8 x 5/16
1.250*	20-S60-104	1/4 X 1/8	2.4375*	30-S60-207	3/8 X 3/16	2.6875*	40-S60-211	5/8 x 5/16
1.1875*	20-S60-103	1/4 X 1/8	2.1875*	30-S60-203	1/2 X 1/4	2.4375*	40-S60-207	5/8 x 5/16
1.125*	20-S60-102	1/4 X 1/8	1.9375*	30-S60-115	1/2 X 1/4	2.1875*	40-S60-203	5/8 x 5/16
1.000*	20-S60-100	1/4 X 1/8	1.6875*	30-S60-111	3/8 X 3/16	SIZE 50		
SIZE 25			1.500*	30-S60-108	3/8 x 3/16	3.4375*	50-S60-307	5/8 x 5/16
2.000*	25-S60-200	1/4 X 1/8	SIZE 35			3.1875*	50-S60-303	5/8 x 5/16
1.9375*	25-S60-115	1/4 X 1/8	2.750	35-S60-212	3/8 X 3/16	2.750	50-S60-212	5/8 x 5/16
1.6875*	25-S60-111	3/8 X 3/16	2.6875*	35-S60-211	3/8 X 3/16	SIZE 60		
1.4375*	25-S60-107	3/8 X 3/16	2.500	35-S60-208	3/8 X 3/16	3.9375*	60-S60-315	3/4 x 3/8
1.250*	25-S60-104	1/4 X 1/8	2.4375*	35-S60-207	5/8 X 5/16	3.4375*	60-S60-307	3/4 x 3/8
1.1875*	25-S60-103	1/4 x 1/8	2.1875*	35-S60-203	1/2 X 1/4	2.9375*	60-S60-215	3/4 x 3/8
			1.9375*	35-S60-115	1/2 x 1/4	SIZE 70 & 80		
			1.6875*	35-S60-111	3/8 x 3/16	4.4375*	80-S60-407	1 x 1/2
						3.9375*	80-S60-315	1 x 1/2

*AGMA Standard
 Bore Tolerance:
 Size 20 thru 35 = +.002 - .000
 Size 40 thru 80 = +.003 - .000

SIZE	C.D.	B +.030 -.030	C	D	E	F	G	H	J +.000 -.001
20	2.000	5.688	3.062	1.855	2.135	1.698	.86	1.666	2.0015
25	2.500	5.812	3.125	1.855	2.197	1.760	.82	1.730	2.6895
30	3.000	7.625	4.062	3.355	2.385	1.885	.98	1.870	3.2838
35	3.500	8.812	4.625	3.980	2.635	2.197	1.10	2.166	3.6900
40	4.000	11.062	5.875	2.980	4.385	3.697	2.26	3.635	4.1900
50	5.000	12.000	6.250	3.980	4.260	3.760	2.27	3.730	4.8775
60	6.000	14.250	7.500	4.980	5.010	4.260	2.52	4.200	5.6275
70	7.000	16.500	8.750	4.980	6.260	5.260	3.43	5.200	7.0025
80	8.000	16.500	8.750	4.980	6.260	5.260	3.43	5.200	7.0025

Size	K +.0005 -.0005	L +.002 -.002	M	N	O	Q	R	S	T	U
20	2.1270	1.937	1.875	.25	5/16 - 24	1/4 x 1/8				.09
25	2.8770	2.625	2.593	.25	5/16 - 24	1/4 x 1/8				.09
30	3.4395	3.250	3.188	.25	5/16 - 24	3/8 x 3/16				.09
35	3.8775	3.625	3.560	.25	5/16 - 24	3/8 x 3/16				.09
40	4.3775	4.000	3.980 - .010	.31	5/16 - 24	5/8 x 5/16	3.18	4.75	.03	.09
50	5.1275	4.750	4.730 - .010	.25	5/16 - 24	5/8 x 5/16	3.75	4.50	.03	.09
60	6.0025	5.500	5.480 - .010	.31	5/16 - 24	3/4 x 3/8	4.75	5.50	.03	.09
70	7.3775	6.875	6.850 - .010	.44	1/2 - 20	1 x 1/2	5.50	6.50	.03	.25
80	7.3775	6.875	6.850 - .010	.44	1/2 - 20	1 x 1/2	5.50	6.50	.03	.25

Cone Drive Standard Hollow Gearshafts

Size 100 to 120

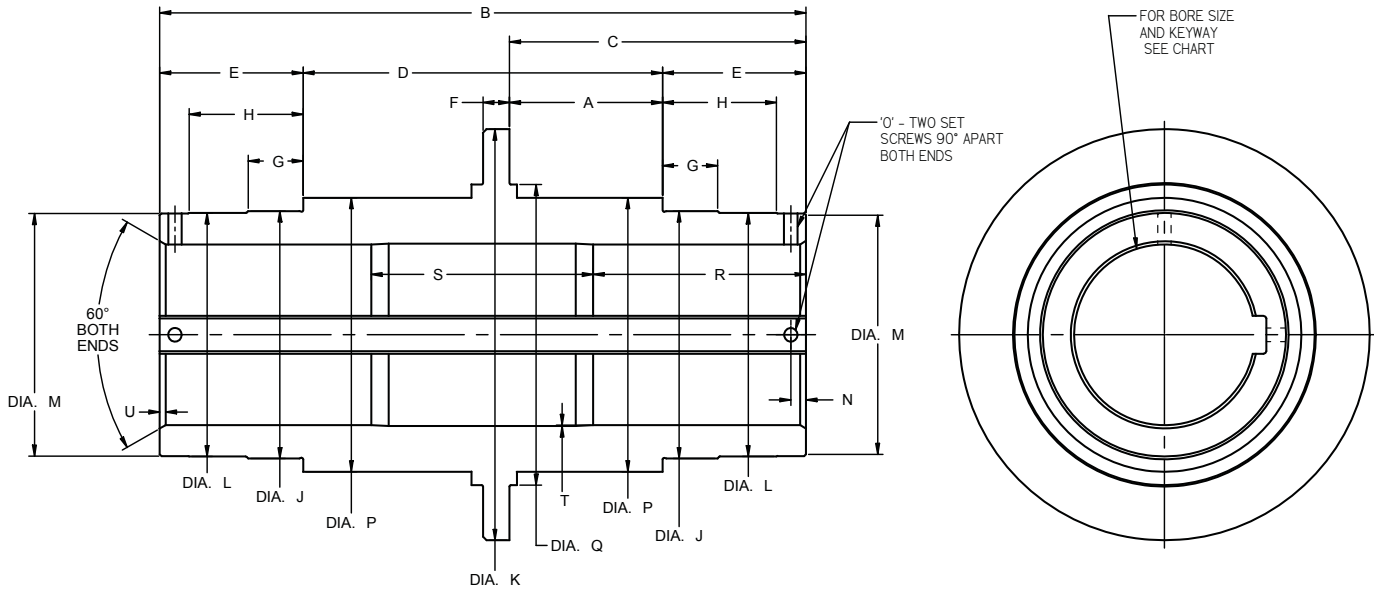

BORE INCHES	GEARSHAFT NUMBER	KEYWAY SIZE
SIZE 100		
5.9375	100-S61-515	1-1/4X7/16
SIZE 120		
7.9375	120-S61-715	1-1/2X1/2

Bore Tolerance:

Size 100 thru 120 = +.004
 -.000

THE SPIDER SHAFT WILL USE A FLANGE TYPE GEAR. PRECEDING IN THIS SECTION, MATERIAL - DUCTILE IRON.

Size	C.D	A ±.003	B	C	D ^{+.010} / _{-.000}	E	F	G	H	J ^{+.000} / _{-.001}
100	10.000	5.906	21.25	10.62	11.812	4.72	.88	1.81	3.75	8.1275
120	12.000	7.375	28.00	14.00	14.750	6.62	1.19	2.25	5.50	10.5050

Size	K ^{+.010} / _{-.000}	L ±.002	M ^{+.000} / _{-.010}	N	O	P	Q	R	S	T	U
100	13.505	8.000	7.975	.50	1/2 - 20	9.25	9.88	7.00	7.25	.03	.19
120	16.508	10.000	9.937	.50	1/2 - 20	11.37	12.62	9.00	10.00	.03	.19

Cone Drive Standard Steeple Gearshaft Mountings and Bearings

Size 25 to 120

Type R Single Extended Single Steeple

Note 1: Type "RU" mounting for vertical shaft, gearshaft extended up. See Note 6.

Note 2: Type "RD" mounting for vertical shaft, gearshaft extended down.

Note 3: When worm is mounted under gear oil level plug is located in carrier so that bearings dip in oil size 40-80. Sizes 100 -120 have grease retainers at each bearing.

Note 4: Grease retainer used on vertical mounted shaft at top end when steeple carrier is at top size 25 thru size 120. When s'd. carrier is at top size 30 thru size 120.

Note 5: Size 35 and larger has a spacer between gear and bearing.

Note 6: For "RU" mounting requiring a vertical base or foot brackets the "Y" and "H" dimensions must be machined to the "X" and "Z" dimensions.

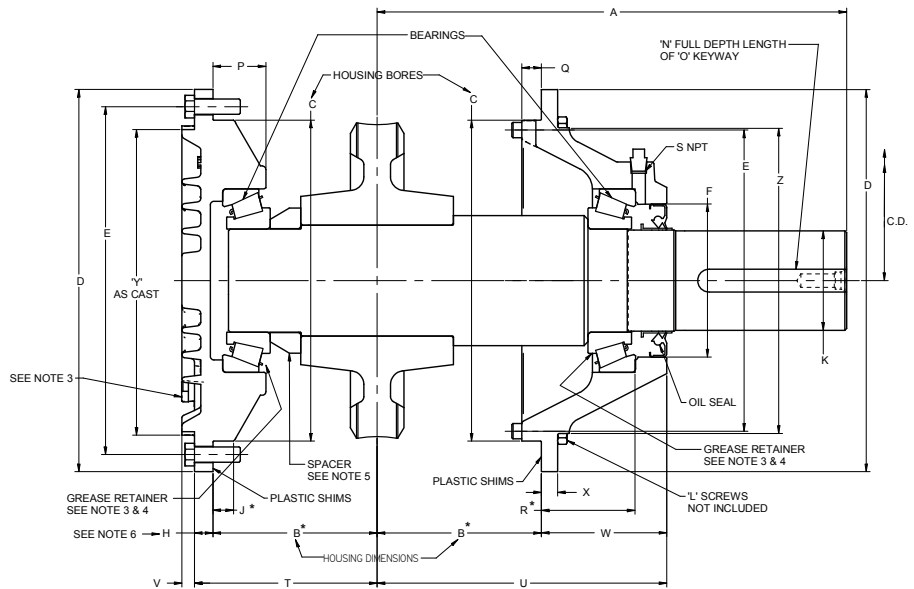

*TOLERANCE FOR			
B	Size	25-80	± .001
		100-120	± .002
J	Size	25-35	± .001
		40-60	± .002
		70-120	± .005
R	Size	25-60	± .002
		70-120	± .005

Size	C.D.	A	B	C	D	E	F	H	J	K	L	N	O	P	Q
25	2.500	7.87	2.000	4.3755 + .0015	5.68	4.94	2.250	.31	.257	1.250	8 - 5/16 - 24	1.38	1/4 x 1/8	.94	.40
30	3.000	8.62	2.625	5.375 + .002	7.00	6.12	2.500	.38	.382	1.500	6 - 3/8 - 24	2.00	3/8 x 3/16	1.03	.50
35	3.500	10.25	3.500	6.500 + .002	8.12	7.25	3.250	.43	.414	1.875	6 - 3/8 - 24	2.68	1/2 x 1/4	1.43	.50
40	4.000	11.25	4.125	7.250 + .002	9.00	8.00	3.750	.43	.385	2.250	6 - 3/8 - 24	3.31	1/2 x 1/4	1.56	.53
50	5.000	13.62	4.750	9.000 + .002	11.00	9.87	4.500	.50	.573	2.750	6 - 1/2 - 20	3.62	5/8 x 5/16	1.87	.59
60	6.000	15.38	5.375	10.500 + .002	12.50	11.38	5.000	.59	.322	3.250	6 - 1/2 - 20	4.50	3/4 x 3/8	1.75	.66
70	7.000	19.38	6.250	12.500 + .002	15.00	13.75	5.250	.68	.806	3.375	6 - 5/8 - 11	4.87	7/8 x 7/16	2.43	.53
80	8.000	19.38	6.250	14.500 + .002	17.12	15.75	5.250	.68	.186	3.500	8 - 5/8 - 11	4.87	7/8 x 7/16	1.31	.50
100	10.000	24.00	8.000	17.750 + .002	20.50	19.12	6.000	.81	.652	4.000	12 - 5/8 - 11	5.12	1 x 1/2	2.03	.50
120	12.000	36.00	10.375	21.500 + .002	24.50	23.00	7.500	.875	.450	5.497	12 - 3/4 - 10	9.62	1-1/4 x 5/8	1.93	.875

SIZE	R	S	T	U	V	W	X	Y	Z	TAPERED ROLLER BEARINGS	OIL SEAL	
25	1.990	1/4	2.31	4.87		2.835	.281		4.218 -.002	02875-CONE	02820-CUP	125W225
30	2.302	1/4	3.06	5.87		3.179	.343		5.343 -.002	26881-CONE	26822-CUP	150W250
35	1.771	1/4	3.81	6.25		2.710	.343		6.468 -.002	33890-CONE	33821-CUP	200W325
40	1.364	1/4	4.62	6.56	.25	2.393	.375	7.12	6.968 -.002	3977-CONE	3920-CUP	231W375
50	2.644	1/4	5.25	8.56	.31	3.730	.437	9.00	8.8125 -.002	567-CONE	563-CUP	281W450
60	3.078	1/4	5.94	9.56	.43	4.107	.531	10.25	9.999 -.002	596-CONE	592A-CUP	331W500
70	5.034	1/4	6.81	12.50	.38	6.174	.625	12.25	11.999 -.002	760-CONE	752-CUP	350W525
80	5.410	1/4	6.87	12.87	.71	6.625	.625	14.25	13.999 -.002	77362-CONE	77675-CUP	356W525
100	6.880	1/4	8.75	16.50	.38	8.500	.750	16.82	16.499 -.003	71412-CONE	71750-CUP	406W600
120	10.714	1/4	11.25	22.6	1.3	12.19	.88	20.50	—	EE107057	107105	550A750

STANDARD GEARSHAFT MOUNTING COMPLETE MOUNTING PARTS - LESS GEAR & SHAFT		SIZE 25	SIZE 30	SIZE 35	SIZE 40	SIZE 50	SIZE 60	SIZE 70	SIZE 80	SIZE 100	SIZE 120
MOUNTING DESCRIPTION	SINGLE EXTENDED - HORIZONTAL WORM UNDER GEAR	25R	30R	35R	40R	50R	60R	70R	80R	100R	120R
	SINGLE EXTENDED - HORIZONTAL WORM OVER GEAR	25RO	30RO	35RO	40RO	50RO	60RO	70RO	80RO	100RO	120RO
	SINGLE EXTENDED - VERTICAL SHAFT UP	25RU	30RU	35RU	40RU	50RU	60RU	70RU	80RU	100RU	120RU
	SINGLE EXTENDED - VERTICAL SHAFT DOWN	25RD	30RD	35RD	40RD	50RD	60RD	70RD	80RD	100RD	120RD

Cone Drive part numbers are shown in bold print. Contact Cone Drive for additional gearshaft dimensions when required.

Cone Drive Standard Steeple Gearshaft Mountings and Bearings

Size 25 to 120

Type S Double Extended – Single Steeple

Note 1: Type “SU” mounting for vertical shaft, longer gearshaft extended up. See Note 6.

Note 2: Type “SD” mounting for vertical shaft, longer gearshaft extended down.

Note 3: When worm is mounted under gear oil level plug is located in carrier so that bearings dip in oil size 40-80. Sizes 100 -120 have grease retainers at each bearing.

Note 4: Grease retainer used on vertical mounted shaft at top end when steeple carrier is at top size 25 thru size 120. When s't'd. carrier is at top size 30 thru size 120.

Note 5: Size 35 and larger has a spacer between gear and bearing.

Note 6: For “SU” mounting requiring a vertical base or foot brackets the “Y” and “H” dimensions must be machined to the “X” and “Z” dimensions.

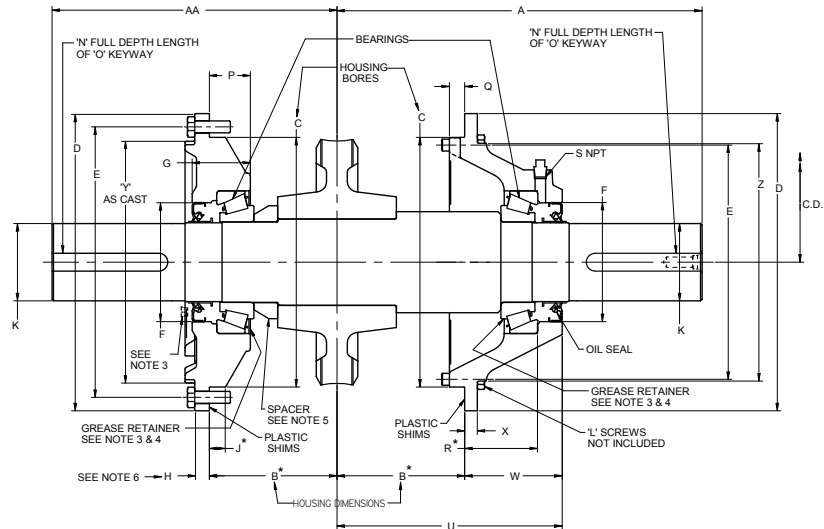

*TOLERANCE FOR			
B	Size	25-80	± .001
		100	± .002
J	Size	25-35	± .001
		40-60	± .002
		70-120	± .005
R	Size	25-60	± .002
		70-120	± .005

Size	C.D.	AA	A	B	C	D	E	F	G	H	J	K	L	N	O
25	2.500	4.50	7.87	2.000	4.3755 + .0015	5.68	4.94	2.250	.860	.31	.257	1.250	8 - 5/16 - 24	1.38	1/4 x 1/8
30	3.000	5.94	8.62	2.625	5.375 + .002	7.00	6.12	2.500	.898	.38	.382	1.500	6 - 3/8 - 24	2.00	3/8 x 3/16
35	3.500	7.87	10.25	3.500	6.500 + .002	8.12	7.25	3.250	.960	.43	.414	1.875	6 - 3/8 - 24	2.68	1/2 x 1/4
40	4.000	9.25	11.25	4.125	7.250 + .002	9.00	8.00	3.750	1.050	.43	.385	2.250	6 - 3/8 - 24	3.31	1/2 x 1/4
50	5.000	10.31	13.62	4.750	9.000 + .002	11.00	9.87	4.500	1.102	.50	.573	2.750	6 - 1/2 - 20	3.62	5/8 x 5/16
60	6.000	12.00	15.38	5.375	10.500 + .002	12.50	11.38	5.000	1.045	.59	.322	3.250	6 - 1/2 - 20	4.50	3/4 x 3/8
70	7.000	13.00	19.38	6.250	12.500 + .002	15.00	13.75	5.250	1.140	.68	.806	3.375	6 - 5/8 - 11	4.87	7/8 x 7/16
80	8.000	14.00	19.38	6.250	14.500 + .002	17.12	15.75	5.250	1.213	.68	.186	3.500	8 - 5/8 - 11	4.87	7/8 x 7/16
100	10.000	15.72	24.00	8.000	17.750 + .002	20.50	19.12	6.000	1.625	.89	.652	4.000	12 - 5/8 - 11	5.12	1 x 1/2
120	12.000	24.00	36.00	10.375	21.500 + .002	24.50	23.00	7.500	12.36	.875	.450	5.497	12 - 3/4 - 10	9.62	1-1/4 x 5/8

SIZE	R	S	T	U	V	W	X	Y	Z	TAPERED ROLLER BEARINGS	OIL SEAL	
25	.94	.40	1.990	1/4	4.87	2.835	.281		4.218 -.002	02875-CONE	02820-CUP	125W225
30	1.03	.50	2.302	1/4	5.87	3.179	.343		5.343 -.002	26881-CONE	26822-CUP	150W250
35	1.43	.50	1.771	1/4	6.25	2.710	.343		6.468 -.002	33890-CONE	33821-CUP	200W325
40	1.56	.53	1.364	1/4	6.56	2.393	.375	7.12	6.968 -.002	3977-CONE	3920-CUP	231W375
50	1.87	.59	2.644	1/4	8.56	3.730	.437	9.00	8.8125 -.002	567-CONE	563-CUP	281W450
60	1.75	.66	3.078	1/4	9.56	4.107	.531	10.25	9.999 -.002	596-CONE	592A-CUP	331W500
70	2.43	.53	5.034	1/4	12.50	6.174	.625	12.25	11.999 -.002	760-CONE	752-CUP	350W515
80	1.31	.50	5.410	1/4	12.87	6.625	.625	14.25	13.999 -.002	77362-CONE	77675-CUP	356W525
100	2.03	.50	6.880	1/4	16.50	8.500	.750	16.82	16.499 -.003	71412-CONE	71750-CUP	406W600
120	1.93	.875	10.714	1/4	22.6	12.19	.88	20.50	—	EE107057	107105	550A750

STANDARD GEARSHAFT MOUNTING COMPLETE MOUNTING PARTS - LESS GEAR & SHAFT		SIZE 25	SIZE 30	SIZE 35	SIZE 40	SIZE 50	SIZE 60	SIZE 70	SIZE 80	SIZE 100	SIZE 120
MOUNTING DESCRIPTION	SINGLE EXTENDED - HORIZONTAL WORM UNDER GEAR	25S	30S	35S	40S	50S	60S	70S	80S	100S	120S
	SINGLE EXTENDED - HORIZONTAL WORM OVER GEAR	25SO	30SO	35SO	40SO	50SO	60SO	70SO	80SO	100SO	120SO
	SINGLE EXTENDED - VERTICAL SHAFT UP	25SU	30SU	35SU	40SU	50SU	60SU	70SU	80SU	100SU	120SU
	SINGLE EXTENDED - VERTICAL SHAFT DOWN	25SD	30SD	35SD	40SD	50SD	60SD	70SD	80SD	100SD	120SD

Cone Drive part numbers are shown in bold print. Contact Cone Drive for additional gearshaft dimensions when required.

Cone Drive Standard Steeple Gearshaft Mountings and Bearings

Size 25 to 120

Type T Double Extended Double Steeple

Note 1: Type "TV" mounting for vertical shaft. Upper bearing has grease retainer.

Note 2: When worm is mounted under gear oil level plug is located in carrier so that bearings dip in oil size 40-80. Size 100-120 have grease retainers at each bearing.

Note 3: Size 35 and larger has a spacer between gear and one bearing.

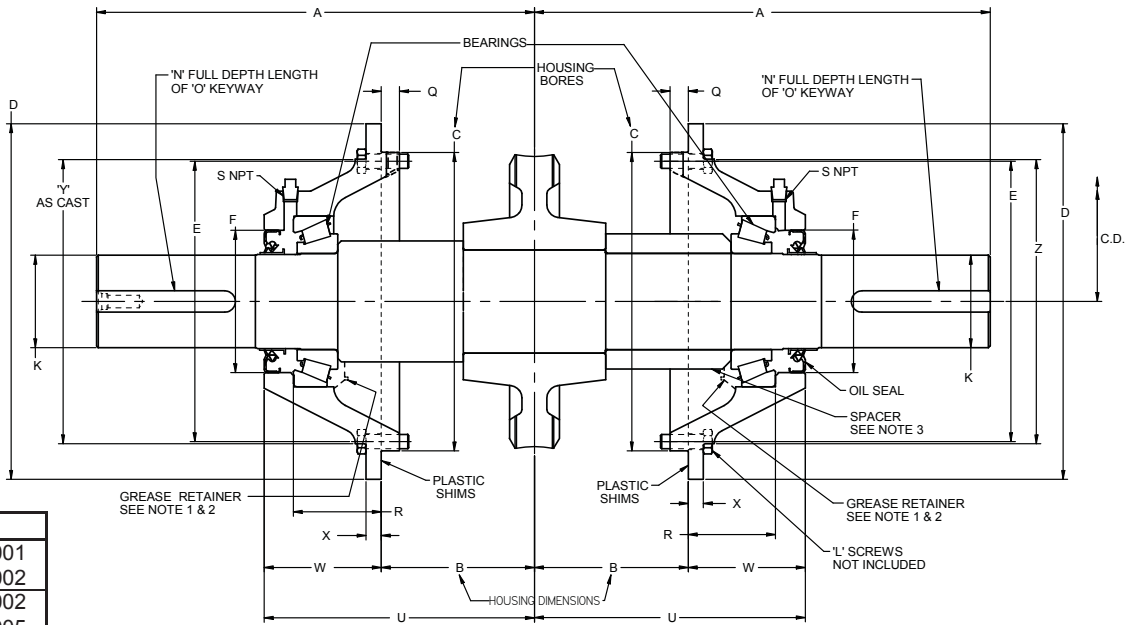

*TOLERANCE FOR			
B	Size	25-80	± .001
		100-120	± .002
R	Size	25-60	± .002
		70-120	± .005

Size	C.D.	A	B	C	D	E	F	K	L	N	O
25	2.500	7.87	2.000	4.3755 + .0015	5.68	4.94	2.250	1.250	8 - 5/16 - 24	1.38	1/4 x 1/8
30	3.000	8.62	2.625	5.375 + .002	7.00	6.12	2.500	1.500	6 - 3/8 - 24	2.00	3/8 x 3/16
35	3.500	10.25	3.500	6.500 + .002	8.12	7.25	3.250	1.875	6 - 3/8 - 24	2.68	1/2 x 1/4
40	4.000	11.25	4.125	7.250 + .002	9.00	8.00	3.750	2.250	6 - 3/8 - 24	3.31	1/2 x 1/4
50	5.000	13.62	4.750	9.000 + .002	11.00	9.87	4.500	2.750	6 - 1/2 - 20	3.62	5/8 x 5/16
60	6.000	15.38	5.375	10.500 + .002	12.50	11.38	5.000	3.250	6 - 1/2 - 20	4.50	3/4 x 3/8
70	7.000	19.38	6.250	12.500 + .002	15.00	13.75	5.250	3.375	6 - 5/8 - 11	4.87	7/8 x 7/16
80	8.000	19.38	6.250	14.500 + .002	17.12	15.75	5.250	3.500	8 - 5/8 - 11	4.87	7/8 x 7/16
100	10.000	24.00	8.000	17.750 + .002	20.50	19.12	6.000	4.000	12 - 5/8 - 11	5.12	1 x 1/2
120	12.000	36.00	10.375	21.500 + .002	24.50	23.00	7.500	5.497	12 - 3/4 - 10	9.62	1-1/4 x 5/8

SIZE	R	S	T	U	V	W	X	Y	Z	TAPERED ROLLER BEARINGS		OIL SEAL
25	.40	1.990	1/4	4.87	2.835	.281	4.218 -.002	02875-CONE	02820-CUP	125W225	02820-CUP	125W225
30	.50	2.302	1/4	5.87	3.179	.343	5.343 -.002	26881-CONE	26822-CUP	150W250	26822-CUP	150W250
35	.50	1.771	1/4	6.25	2.710	.343	6.468 -.002	33890-CONE	33821-CUP	200W325	33821-CUP	200W325
40	.53	1.364	1/4	6.56	2.393	.375	6.968 -.002	3977-CONE	3920-CUP	231W375	3920-CUP	231W375
50	.59	2.644	1/4	8.56	3.730	.437	8.8125-.002	567-CONE	563-CUP	281W450	563-CUP	281W450
60	.66	3.078	1/4	9.56	4.107	.531	9.999 -.002	596-CONE	592A-CUP	331W500	592A-CUP	331W500
70	.53	5.034	1/4	12.50	6.174	.625	11.999 0 .002	760-CONE	752-CUP	350W525	752-CUP	350W515
80	.50	5.410	1/4	12.87	6.625	.625	13.999 0 .002	77362-CONE	77675-CUP	356W525	77675-CUP	356W525
100	.50	6.880	1/4	16.50	8.500	.750	16.499 -.003	71412-CONE	71750-CUP	406W600	71750-CUP	406W600
120	.875	10.714	1/4	22.6	12.19	.88	—	EE107057	107105	550A750	107105	550A750

STANDARD GEARSHAFT MOUNTING COMPLETE MOUNTING PARTS - LESS GEAR & SHAFT		SIZE 25	SIZE 30	SIZE 35	SIZE 40	SIZE 50	SIZE 60	SIZE 70	SIZE 80	SIZE 100	SIZE 120
MOUNTING DESCRIPTION	SINGLE EXTENDED - HORIZONTAL WORM UNDER GEAR	25T	30T	35T	40T	50T	60T	70T	80T	100T	120T
	SINGLE EXTENDED - HORIZONTAL WORM OVER GEAR	25TO	30TO	35TO	40TO	50TO	60TO	70TO	80TO	100TO	120TO
	SINGLE EXTENDED - VERTICAL SHAFT	25TV	30TV	35TV	40TV	50TV	60TV	70TV	80TV	100TV	120TV

Cone Drive part numbers are shown in bold print. Contact Cone Drive for additional gearshaft dimensions when required.

Cone Drive Pump and Worm Mountings

Size 40 to 80

Standard "FA" Mounting for Models HU and HV Size 40F thru 80F, HO 40F thru 60F,
 "FAO" Mounting for HO 70F - 80F.

NOTE 1: WORM OVER GEAR MODEL HO 70F & 80F UNITS MOUNTING AO REQUIRE CLOSED OIL GROOVES AS SHOWN.

NOTE 2: FOR DIMENSIONS NOT SHOWN SEE STANDARD MOUNTING SECTION.

NOTE 3: MOUNTING CAN BE FURNISHED WITH OR WITHOUT PUMP, PRICED ACCORDINGLY.

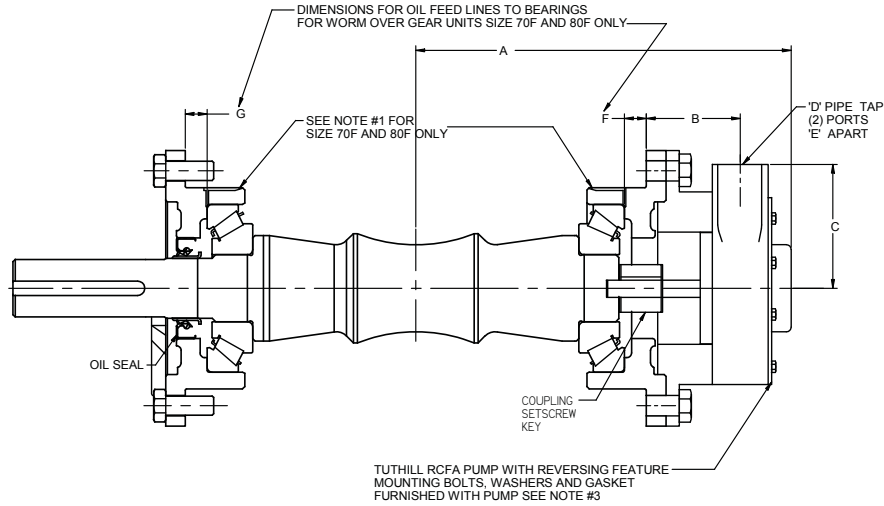

Size	C.D.	A	B	C	D	E	F	G	H	PUMP INFORMATION			
										CONE NUMBER	TUTHILL NUMBER	CAPACITY AT 50	
												1800 RPM	1200 RPM
40F	4.000	10.12	2.84	3.68	1" NPT	3.12				186000	#2	8 GPM	6 GPM
50F	5.000	10.96	2.93	3.68	1" NPT	3.12				186000	#2	8 GPM	6 GPM
60F	6.000	11.42	2.76	3.68	1" NPT	3.12				186000	#2	8 GPM	6 GPM
70F	7.000	12.875	2.54	4.87	1 1/4 NPT	4.12	1.80	1.80		186001	#3	17 GPM	11.5 GPM
80F	8.000	14.250	2.54	4.87	1 1/4 NPT	4.12	2.25	2.25		186001	#3	17 GPM	11.5 GPM

PUMP MOUNTING COMPLETE MOUNTING PARTS - LESS WORM	SIZE 40F	SIZE 50F	SIZE 60F	SIZE 70F	SIZE 80F
SINGLE EXTENDED STANDARD	P40FA	P50FA	P60FA	P70FA	P80FA
SINGLE EXTENDED WORM OVER				P70FAO	P80FAO

Cone Drive Pump and Worm Mountings

Size 100 to 180

Standard "A" Mounting for Model HU Size 100 thru 180 and Model HV Size 100 thru 180

Standard "AO" Mounting for Model HO Size 100 thru 180

NOTE 1: WORM OVER GEAR
 MODEL HO UNITS MOUNTING AO, REQUIRE CLOSED OIL GROOVES AS SHOWN, SIZE 100 THRU 180.

NOTE 2: FOR DIMENSIONS NOT SHOWN SEE STANDARD WORM MOUNTINGS.

NOTE 3: ADAPTOR CAP FOR PUMP MAY BE MADE AS TWO PIECES INSTEAD OF ONE AS SHOWN.

NOTE 4: MOUNTING CAN BE FURNISHED WITH OR WITHOUT PUMP, PRICED ACCORDINGLY.

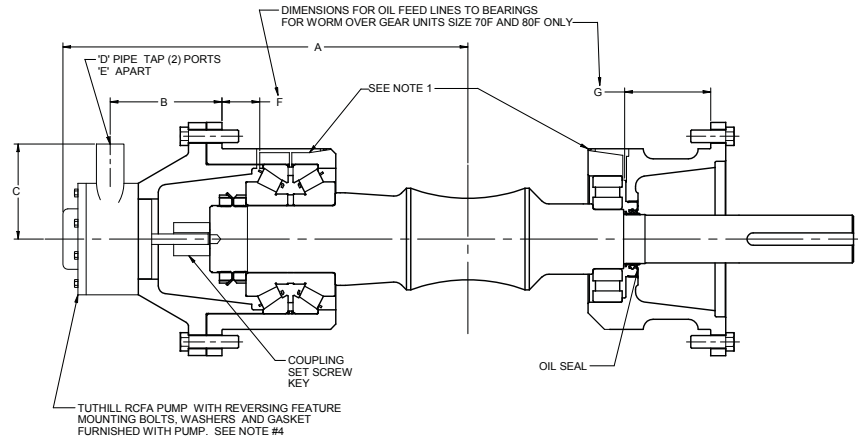

Size	C.D.	A	B	C	D	E	F	G	H	PUMP INFORMATION			
										CONE NUMBER	TUTHILL NUMBER	CAPACITY AT 50	
												1800 RPM	1200 RPM
100	10.000	19.81	5.25	4.87	1 1/4 NPT	4.12	3.25	4.38		186001	#3	17 GPM	11.5 GPM
120	12.000	23.75	6.59	4.12	1 1/2 NPT	3.75	3.75	5.19		186002	#4	36 GPM	23.5 GPM
150	15.000	26.75	7.34	4.12	1 1/2 NPT	3.75	3.50	4.87	3.75	186002	#4	36 GPM	23.5 GPM
180	18.000	27.87	6.72	4.12	1 1/2 NPT	3.75	4.38	5.50	4.09	186002	#4	36 GPM	23.5 GPM

PUMP MOUNTING COMPLETE MOUNTING PARTS - LESS WORM	SIZE 100	SIZE 120	SIZE 150	SIZE 180
SINGLE EXTENDED STANDARD	P100A	P120A	P150A	P180A
SINGLE EXTENDED WORM OVER	P100AO	P120AO	P150AO	P180AO



Cone Drive Family of Products



Model HP

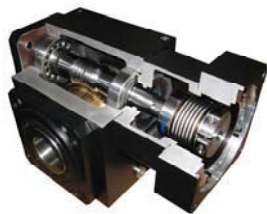

AccuDrive



Gearsets

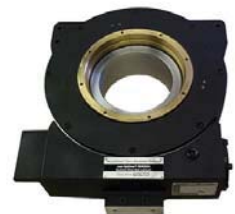

Specials



CONEDRIVE™
GEARING SOLUTIONS

Cone Drive Operations, Inc
240 E. 12th Street,
Traverse City, MI. 49685

Sales: 1-888-994-2663
Sales Fax: 1-888-907-2663